

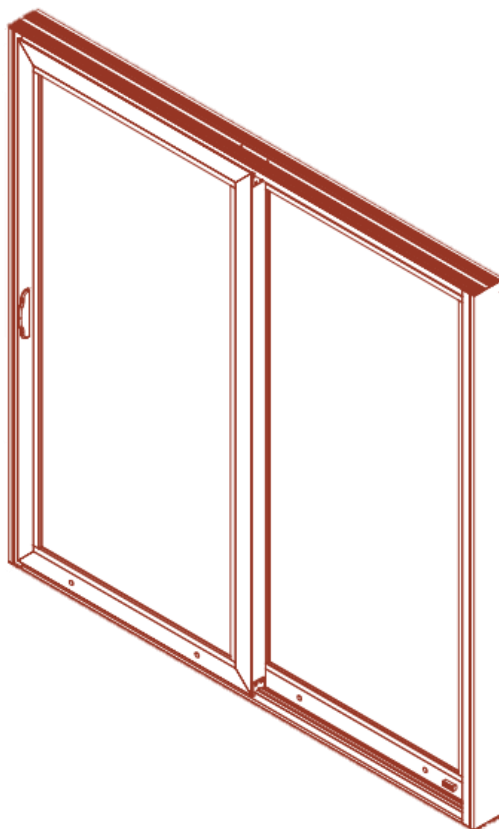

INSTALLADOR CERTIFICADO

MANUAL DE INSTALACION DE PUERTA CORREDIZA SERIE MG-1000



INTRODUCCION

Estas instrucciones se ofrecen como una guía de instalación. El Florida Approval del producto debe utilizarse juntamente con esta guía. Únicamente instaladores profesionales y experimentados deben acometer los trabajos relativos a esta instalación.

Lea todas las instrucciones atentamente. En caso de dudas contactar a The Installation Champions, instaladores certificados de America's Best Windows and Doors.

Utilice todo el equipo de protección necesario y tome las precauciones de seguridad requeridas en dependencia de las características de instalación, especialmente las relativas al trabajo en alturas si fuera el caso.

TIPO DE INSTALACION

Utilice el tipo de anclaje dependiendo del sustrato. Seguir las instrucciones en el Florida Approval, con respecto a la distancia, espacios y espacio del calzado.

Aplique silicona en los orificios antes de insertar los anclajes, y encima de ellos, una vez apretado asegúrese de que el marco está nivelado y plomada.

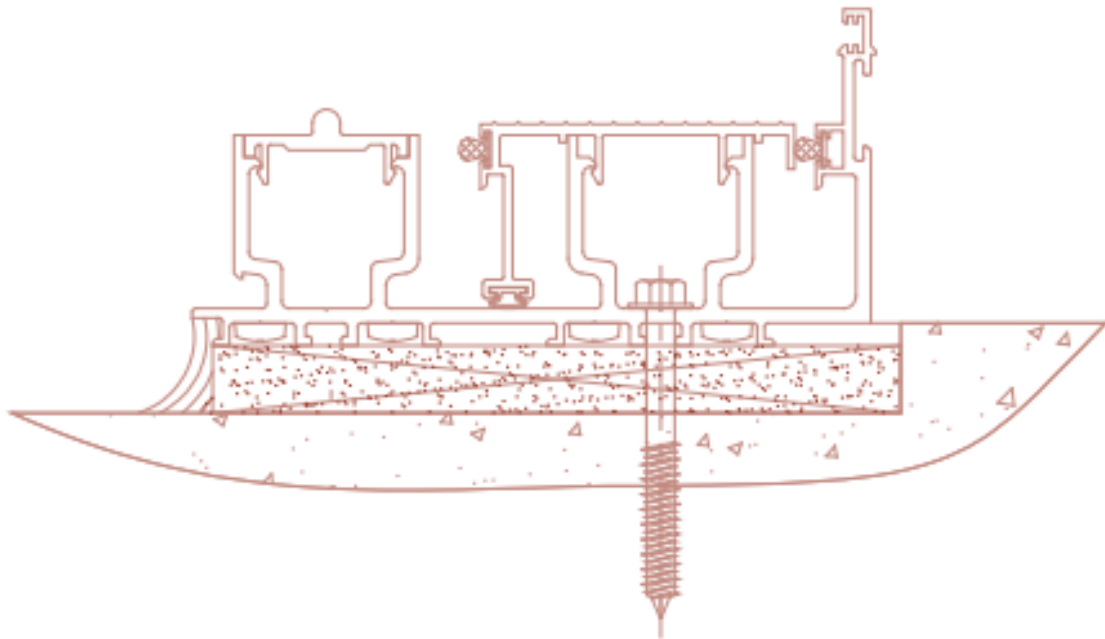

1. INSPECCION DEL OPENING

Este es el primer paso con independencia del tipo de instalación de que se trate. En ambos casos

a) Verificar que el vano de albañilería tiene las dimensiones correctas, esta escuadra, aplomado y en un único plano. No más de 1/4" de diferencia en la escuadra (diferencia entre las diagonales), ancho o alto, ni más de 1/8" de nivel serán aceptados. Remediar cualquier problema.

b) Inspeccionar el "opening" en cuanto a mortero faltante, cracks o rajaduras en el sill que creen un vacío o cavidad que permita la infiltración de agua o humedad. También se debe limpiar de cualquier exceso de mortero o residuo. Remediar cualquier problema.

c) The Installation Champions recomienda que a partir del sill de la puerta corrediza, exista una pendiente que permita el rápido drenaje del agua que sea evacuada por el sistema.

Asegurarse de que los drenajes no queden por debajo del nivel del piso adyacente y que las pendientes no están invertidas. Esto invalida la garantía sobre el funcionamiento de la puerta.

d) Verificar los dibujos propiciados en este manual y asegurarse de que la preparación del vano esta conforme a las especificaciones.

En caso de instalaciones con bucks de madera asegurarse de que todos están sellados correctamente y que todos los bucks (en caso de que exista) están en un mismo plano. En caso de detectarse algún problema **NO INSTALAR** hasta que a quien corresponda realice las correcciones necesarias.

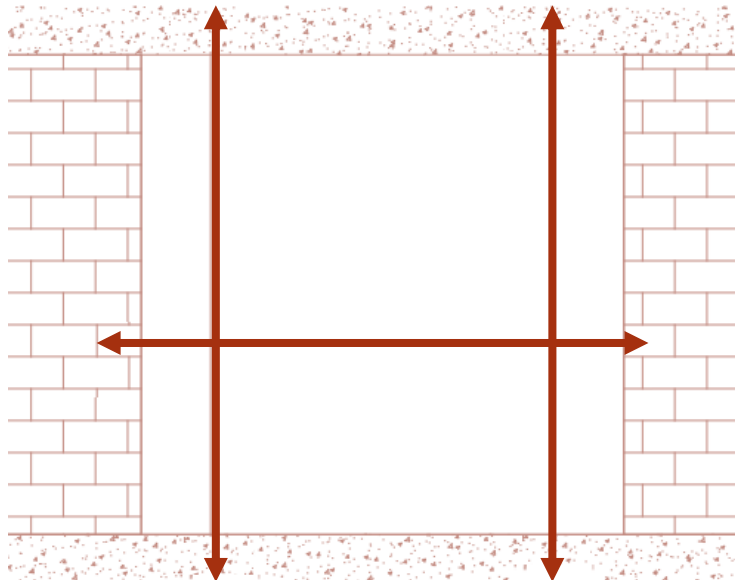

2. DESEMBALAJE DE LA PUERTA

- a) Retirar el retractilado y los cartones cuidadosamente. No utilizar cuchillas ni herramientas con filo o punta que pudieran rayar el cristal o el acabado del aluminio.
- b) Separar y guardar los covers. Estos covers no deben ser instalados hasta que la inspección de la colocación de los anclajes se haya realizado.
- c) El marco se entrega en un paquete separado junto con el resto de los accesorios. Verifique el contenido del paquete antes de comenzar el ensamblado. Compruebe las piezas y accesorios que debe tener dependiendo de la configuración de la puerta.
- d) Los paneles están etiquetados para su identificación. Consultar páginas 89- 92 para el tipo de panel requerido dependiendo de la configuración.

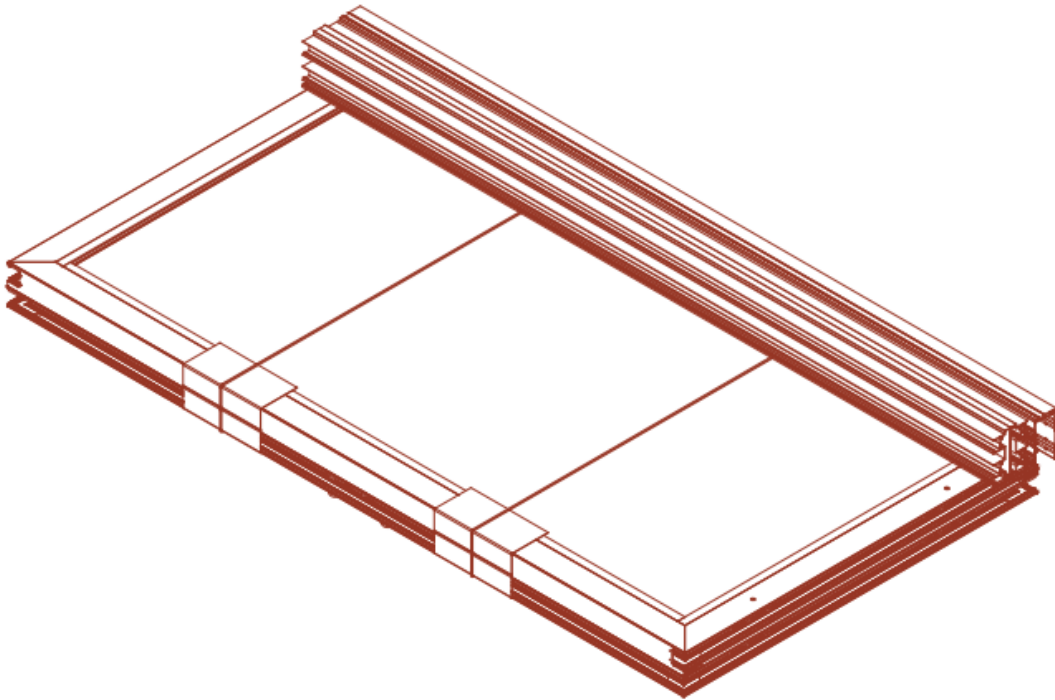

3. MONTAJE DEL MARCO

a) Aplicar silicona adecuada en las siguientes zonas:

-Junta entre jambs y sill, y jambs y head.

-En la ubicación del tornillo de montaje (16 u x #10) y encima de los tornillos.

-Sello vertical entre la parte posterior de los jambs y el sill.

b) Antes de ensamblar el marco, deslice en el sill & head el puente de estanqueidad. Ver detalle B.

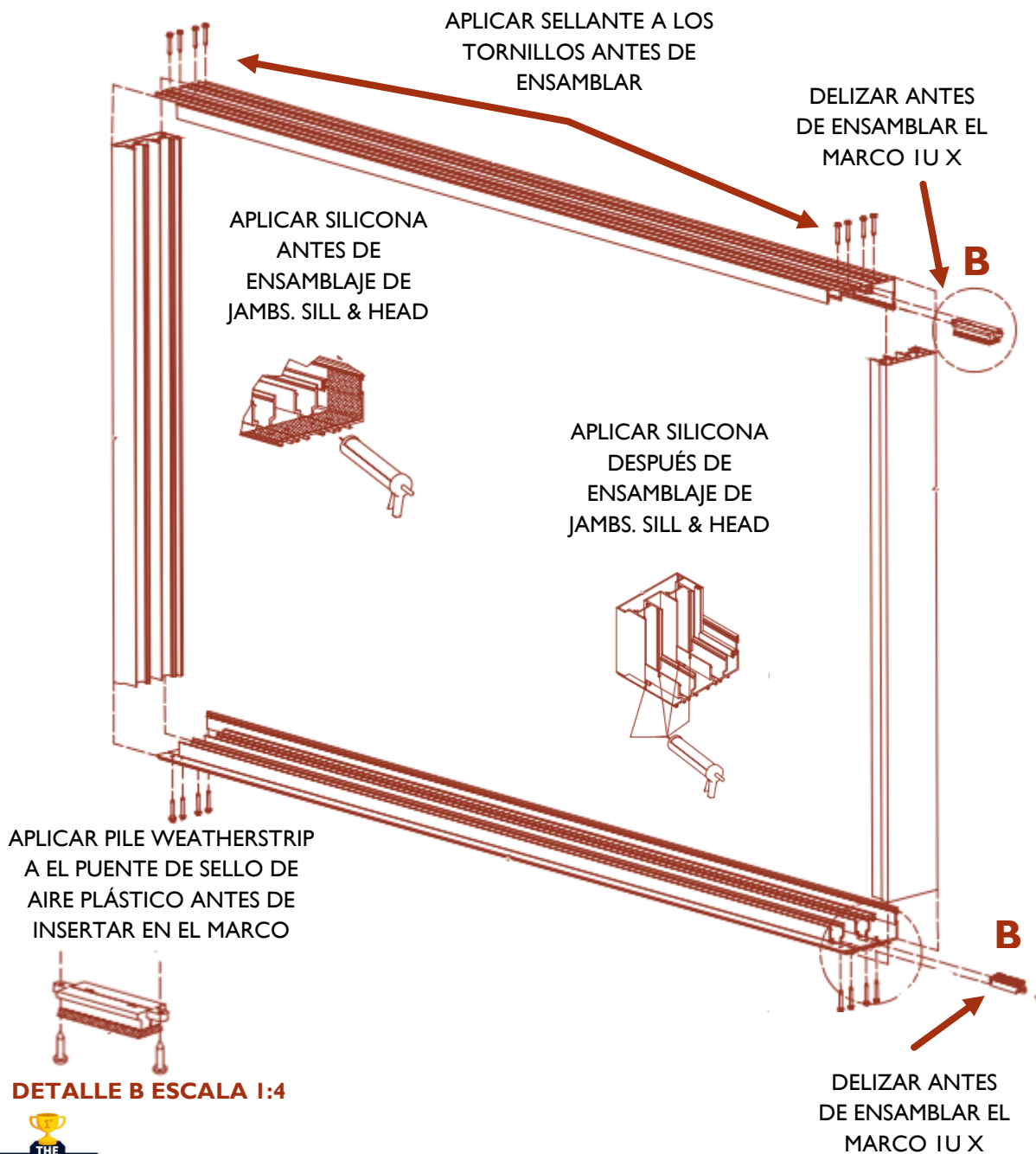

4. TRACK AT SILL & SNAP COVER AT HEAD

- a) Espere la inspección antes de colocar el head snap cover y sill track, para que que el funcionario de construcción pueda inspeccionar los anclajes.
- b) Instale el sill track como se indica en el manual dependiendo de la configuración.
- c) Aplique sellador en los extremos para evitar que el agua entre al sill track.

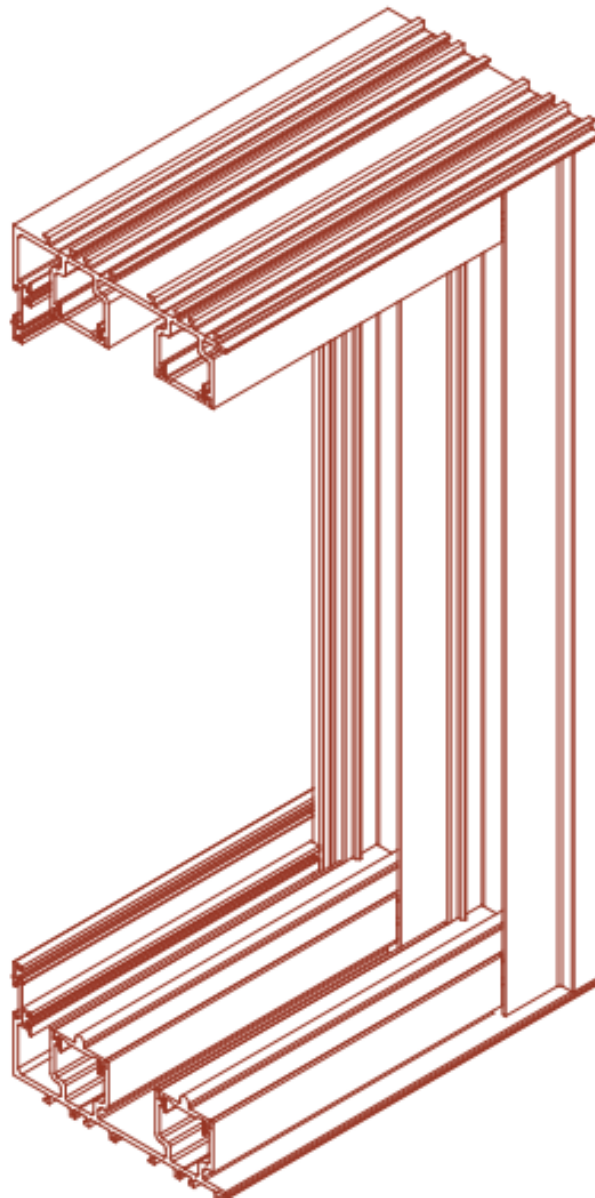

5. INSTALACION DE PANELES

a) Dependiendo de la configuración de la puerta tendrá que utilizar una configuración de panel diferente. Consulte la página 89-92 para compruebe el nombre del panel de A a PGR que se aplican a su proyecto.

b) Los paneles están etiquetados para facilitar la identificación. Todos nuestros paneles, móviles o no, se suministran con rodillos para facilitar la instalación. Los orificios de acceso para ajuste se encuentran en la parte inferior, la cara exterior del panel.

c) El puente de sellado que se insertó en el paso 3 están diseñados para evitar que los paneles se puedan desmontar desde el exterior. Su posición final está justo debajo y arriba del interlock entre paneles. También son extremadamente importantes para la estanqueidad al aire y agua de la puerta. Para ser capaz de instalar los paneles **ESTOS NO PUEDEN ESTAR EN LA POSICION FINAL**, mueva el puente del sello de aire a un lado u otro

d) Una vez instalados los paneles, mueva el puente del sello de aire justo debajo del interlock, asegúrelos en su lugar con #10 tornillos y sellar alrededor

e) Tenga en cuenta que los paneles fijos están provistos de bumpers en los verticales que se encuentran con los Jamb. Mueva los paneles hacia los jamb hasta que el bumper toque el jamb. Eso pondrá los paneles fijos en su posición.

f) Ajuste la altura de los rollers para compensar cualquier falta de nivel o plomo.

NOTE QUE las configuraciones OXO Y OXXO se entregan con el astragal instalado en el panel. TIENE QUE SER REMOVIDO PARA LA INSTALACION DEL PANEL y reinstalado después.

g) Instale las guías de plástico en los paneles (2 en la parte superior y 2 en inferior).

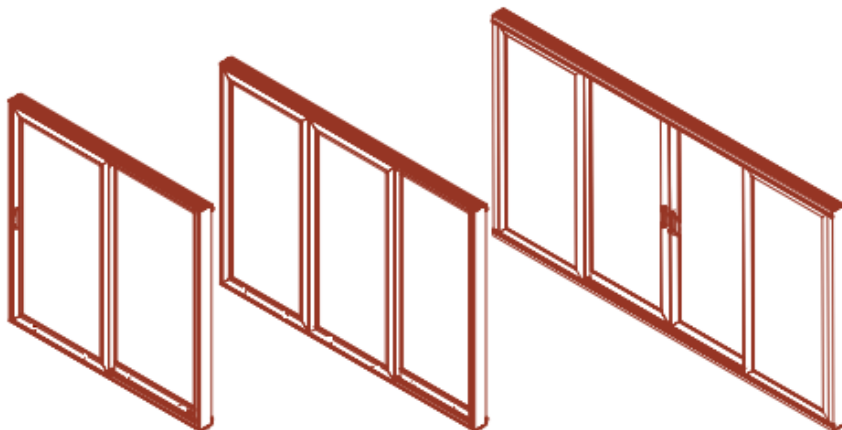

6. INSTALACION DE LOS COVERS

- a) Una vez que los paneles están en su lugar y las guías instaladas, proceder a colocar en su lugar los covers.
- b) Todas las configuraciones excepto XX necesitan un cover horizontal en el sill y el head. El final de los covers debe ser sellado para que coincida con el weather strip en el cover vertical y la junta en los jams.
- c) Instale los covers verticales interiores (cuando sea necesario dependiendo en la configuración) y aplicar sellador entre ellos y los covers horizontales.
- d) Instale los covers verticales exteriores. Estos son decorativos y no se requiere sellador en ellos.

7. INSTALACION DE EL HANDLE

- a) Para instalar el handle, siga las instrucciones del fabricante del hardware.
- b) Tenga en cuenta que el striker tiene ajuste en dirección "arriba y abajo".
- c) El striker también permite un cierto ajuste lateral para acercar o alejar los paneles al jamb (OX,XX,XOX,OXO,OXXO). Una vez en la posición final, fijar en su lugar.

8. SELLO FINAL

- a) Después de completar la instalación de la puerta, comprobar que todos los sellos están bien hechos. Siga las instrucciones en las páginas APPLICATION OF SILICONE INSTRUCTION dependiendo de la configuración.
- b) Asegúrese específicamente de:
 - Aplicar silicona en el sill/Head (todas las configuraciones excepto la XX)
 - Compruebe el sellador de silicona entre el cover horizontal en sill y el panel adyacente o covers verticales en el jamb, dependiendo de la configuración

9. SILL RAISER

- a) Está instalando una puerta corredera de vidrio extremadamente eficaz en términos de infiltración en fugas de agua. **NO SE REQUIERE NINGÚN SILL RAISER EXCEPTO PARA CONFIGURACIONES XX EN DP>70PSF.**
- b) Si se requiere un sill raiser, aplique silicona generosamente en la pared posterior del sill, donde va montado el riser antes de instalarlo.





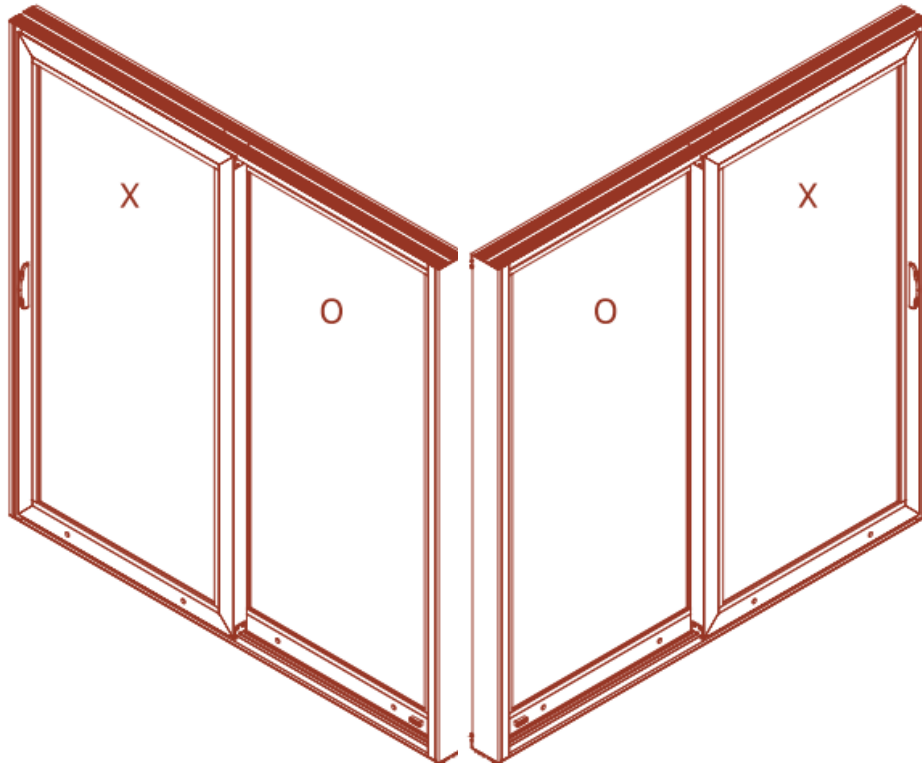









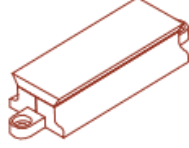

XO & OX KD PACQUETE



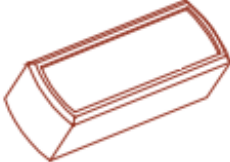

PARA CONFIGURACIONES XO VER PAGINAS 89-92 PARA SELECCIÓN DE TIPO DE PANEL

# Parte	Descripción	Imagen
1	Sill (1U)	
2	Head (1U)	
3	Jambs (2U)	

4	Hex Head #12 x 1 1/2" SMS. AISI 410 (16U)	
5	Track Short (1U)	
6	Track Long (1U)	
7	Flat Cover Long (1U)	
8	Flat Cover Short (1U)	
9	Vertical Cover (2U)	
10	Horizontal Cover (2U)	
11	Air Seal Bridge (2U)	

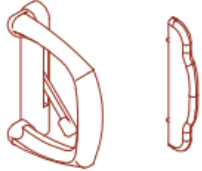
12	Panels (2U)	
13	Bumper (1U)	
14	PH-FH #10-16 x 3/4" SMS, AISI 316 (16U)	
15	Roller Adjust Hole Plug (4U)	
16	Bottom Panel Guide (2U)	
17	Top Panel Guide (2U)	
18	Striker (1U)	

19	Lock Handle set (1U)	
20	PH-PH #10-16 x 1/2" SMS. AISI 316 (4U)	
21	PH-PH #10-16 x 1" Self Drilling. AISI 410 (8U)	

XO AND OX TRACK INSTRUCCIONES

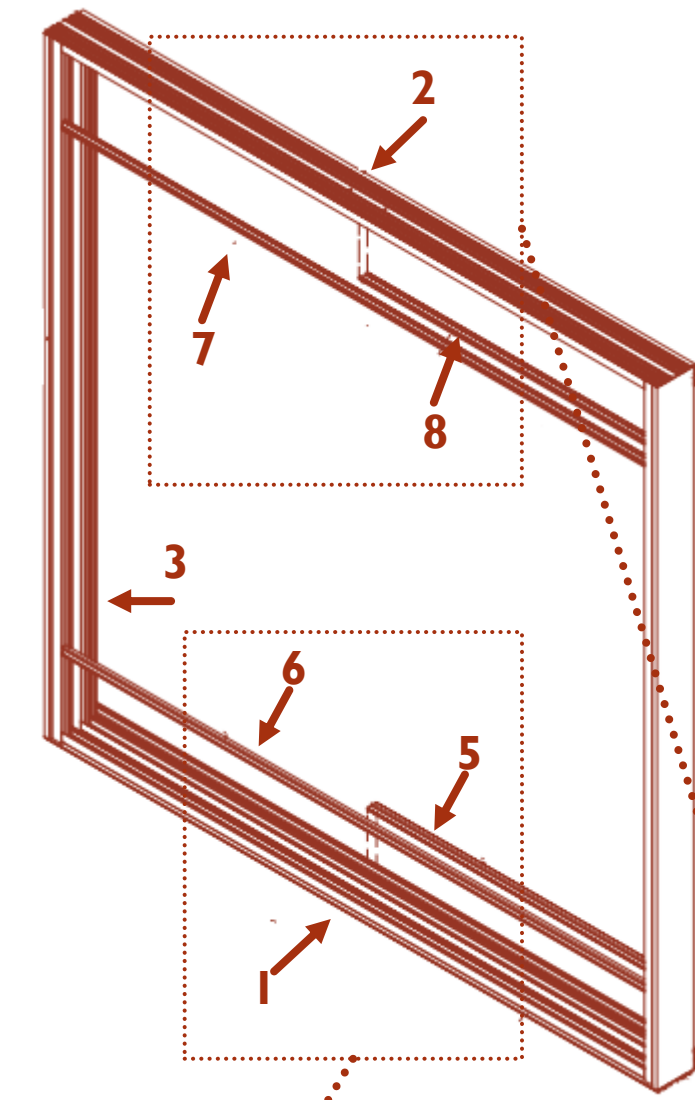

# Parte	Descripción
1	Sill (1U)
2	Head (1U)
3	Jambs (2U)
4	Hex Head #12 x 1 1/2" SMS. AISI 410 (16U)
5	Track Short (1U)
6	Track Long (1U)
7	Flat Cover Long (1U)
8	Flat Cover Short (1U)
9	Vertical Cover (2U)
10	Horizontal Cover (2U)
11	Air Seal Bridge (2U)
12	Panels (2U)
13	Bumper (1U)
14	PH-FH #10-16 x 3/4" SMS, AISI 316 (16U)
15	Roller Adjust Hole Plug (4U)
16	Bottom Panel Guide (2U)
17	Top Panel Guide (2U)
18	Striker (1U)
19	Lock Handle set (1U)
20	PH-PH #10-16 x 1/2" SMS. AISI 316 (4U)
21	PH-PH #10-16 x 1" Self Drilling. AISI 410 (8U)

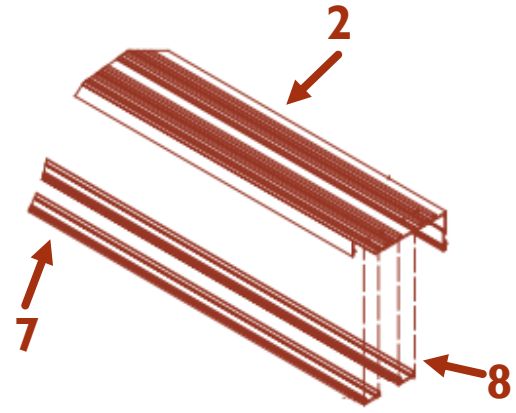
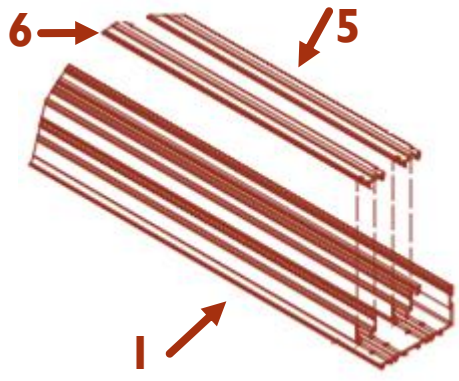

XO AND OX PANEL INSTRUCCIONES

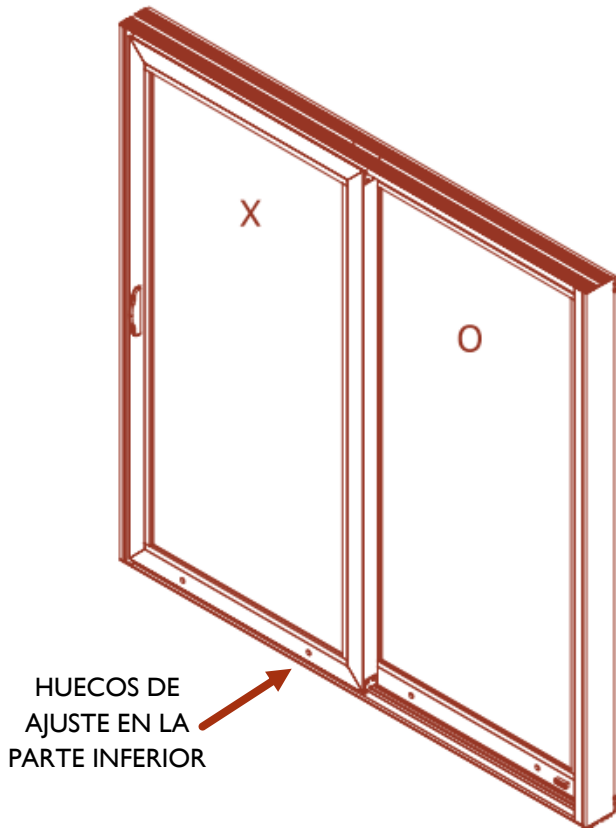

# Parte	Descripción
1	Sill (1U)
2	Head (1U)
3	Jams (2U)
4	Hex Head #12 x 1 1/2" SMS. AISI 410 (16U)
5	Track Short (1U)
6	Track Long (1U)
7	Flat Cover Long (1U)
8	Flat Cover Short (1U)
9	Vertical Cover (2U)
10	Horizontal Cover (2U)
11	Air Seal Bridge (2U)
12	Panels (2U)
13	Bumper (1U)
14	PH-FH #10-16 x 3/4" SMS, AISI 316 (16U)
15	Roller Adjust Hole Plug (4U)
16	Bottom Panel Guide (2U)
17	Top Panel Guide (2U)
18	Striker (1U)
19	Lock Handle set (1U)
20	PH-PH #10-16 x 1/2" SMS. AISI 316 (4U)
21	PH-PH #10-16 x 1" Self Drilling. AISI 410 (8U)

POSICIÓN DE PANELES

POSICIÓN DEL AIR SEAL BRIDGE EN EL SILL & HEAD, NO PUEDE ESTAR EN LA POSICIÓN FINAL DURANTE LA INSTALACIÓN DE LOS PANELES

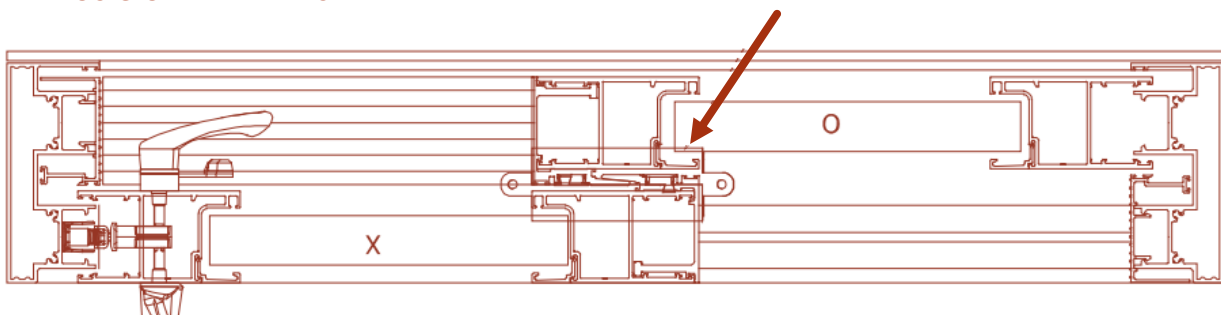

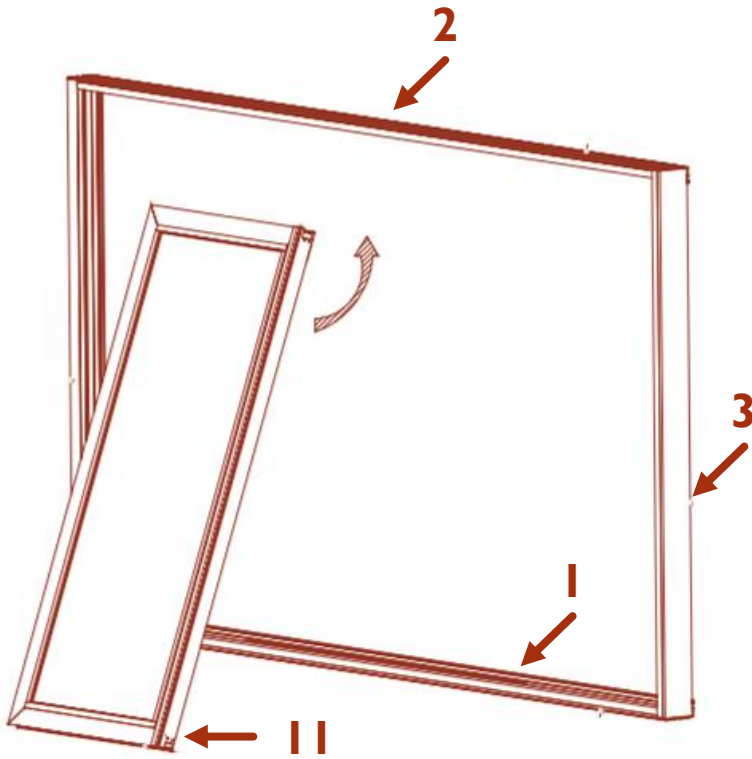

# Parte	Descripción
1	Sill (1U)
2	Head (1U)
3	Jambs (2U)
4	Hex Head #12 x 1 1/2" SMS. AISI 410 (16U)
5	Track Short (1U)
6	Track Long (1U)
7	Flat Cover Long (1U)
8	Flat Cover Short (1U)
9	Vertical Cover (2U)
10	Horizontal Cover (2U)
11	Air Seal Bridge (2U)
12	Panels (2U)
13	Bumper (1U)
14	PH-FH #10-16 x 3/4" SMS. AISI 316 (16U)
15	Roller Adjust Hole Plug (4U)
16	Bottom Panel Guide (2U)
17	Top Panel Guide (2U)
18	Striker (1U)
19	Lock Handle set (1U)
20	PH-PH #10-16 x 1/2" SMS. AISI 316 (4U)
21	PH-PH #10-16 x 1" Self Drilling. AISI 410 (8U)

NOTA: TODOS LOS PANELES SON INSTALADOS DE LA MISMA MANERA PARA LA POSICIÓN DE LOS PANELES DE LA CONFIGURACIÓN XO, VER PÁGINA **TIPO DE PANELES**

XO AND OX COVERS INSTRUCCIONES

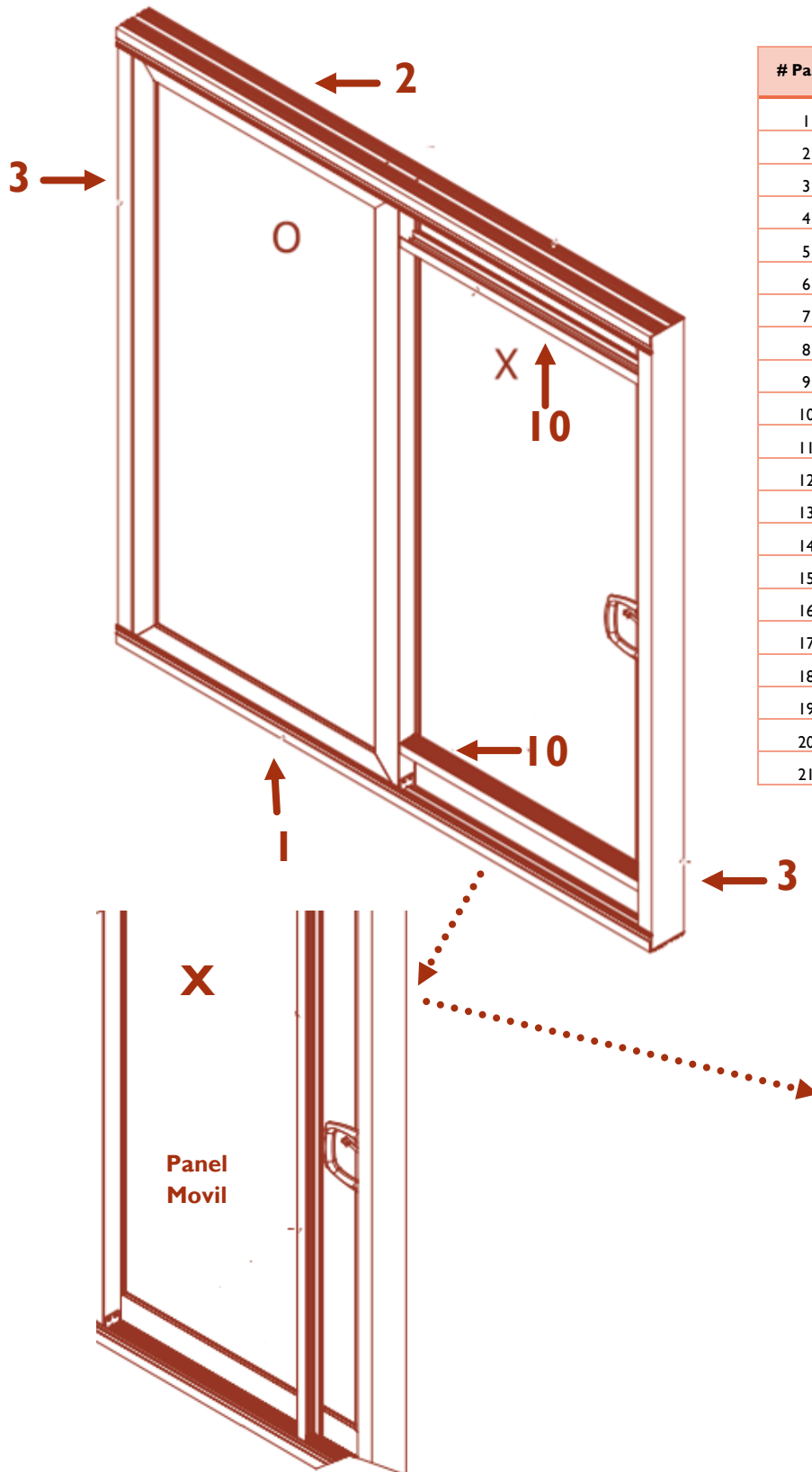

# Parte	Descripción
1	Sill (1U)
2	Head (1U)
3	Jambs (2U)
4	Hex Head #12 x 1 1/2" SMS. AISI 410 (16U)
5	Track Short (1U)
6	Track Long (1U)
7	Flat Cover Long (1U)
8	Flat Cover Short (1U)
9	Vertical Cover (2U)
10	Horizontal Cover (2U)
11	Air Seal Bridge (2U)
12	Panels (2U)
13	Bumper (1U)
14	PH-FH #10-16 x 3/4" SMS, AISI 316 (16U)
15	Roller Adjust Hole Plug (4U)
16	Bottom Panel Guide (2U)
17	Top Panel Guide (2U)
18	Striker (1U)
19	Lock Handle set (1U)
20	PH-PH #10-16 x 1/2" SMS. AISI 316 (4U)
21	PH-PH #10-16 x 1" Self Drilling. AISI 410 (8U)

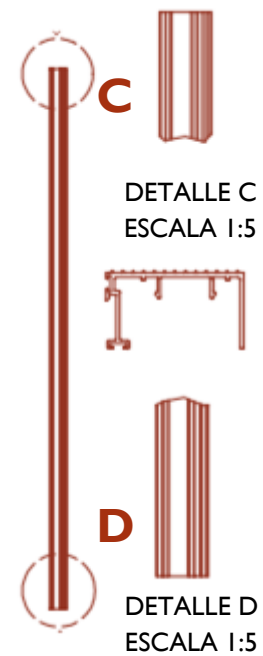

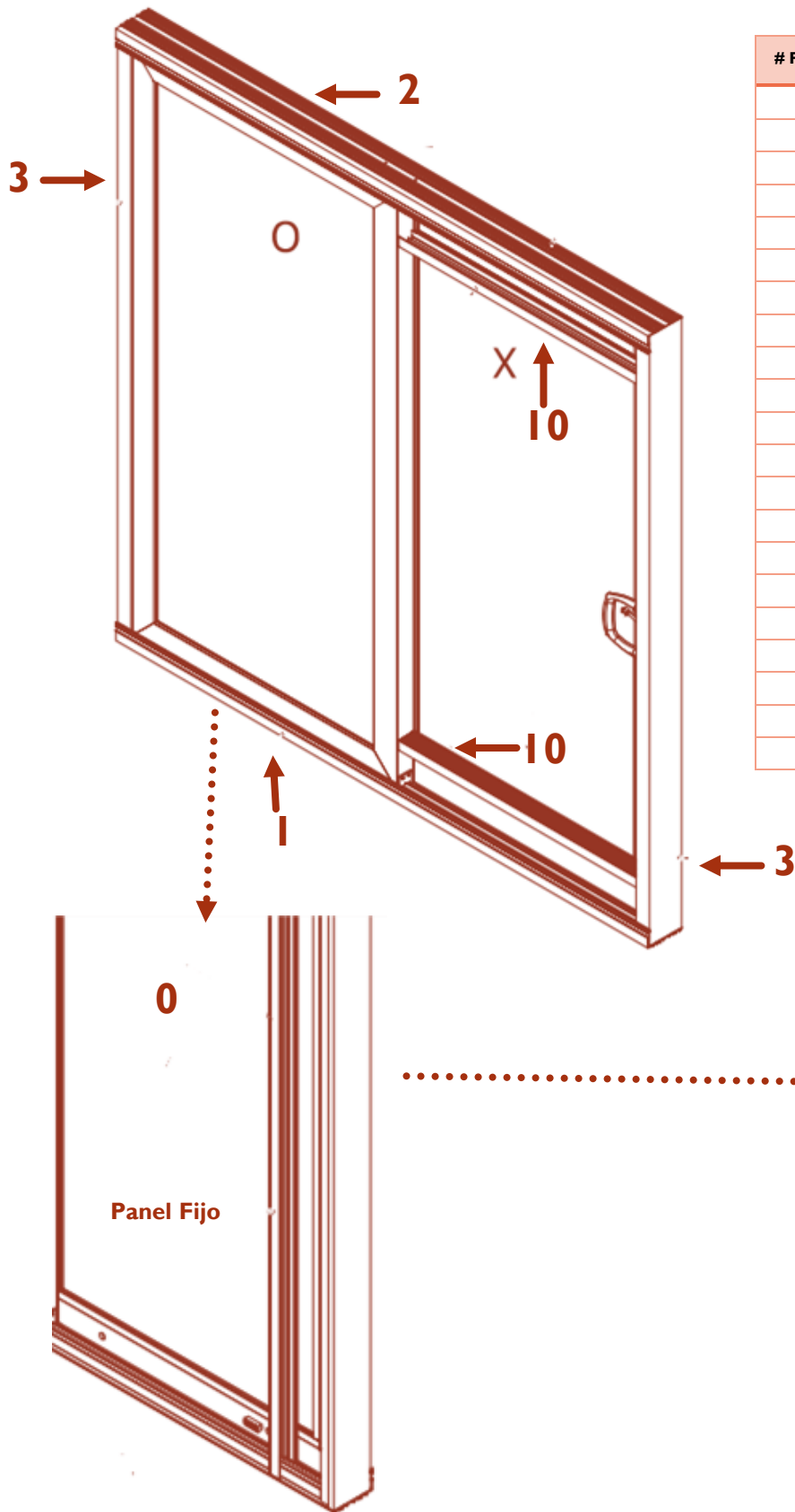

# Parte	Descripción
1	Sill (1U)
2	Head (1U)
3	Jamb (2U)
4	Hex Head #12 x 1 1/2" SMS. AISI 410 (16U)
5	Track Short (1U)
6	Track Long (1U)
7	Flat Cover Long (1U)
8	Flat Cover Short (1U)
9	Vertical Cover (2U)
10	Horizontal Cover (2U)
11	Air Seal Bridge (2U)
12	Panels (2U)
13	Bumper (1U)
14	PH-FH #10-16 x 3/4" SMS, AISI 316 (16U)
15	Roller Adjust Hole Plug (4U)
16	Bottom Panel Guide (2U)
17	Top Panel Guide (2U)
18	Striker (1U)
19	Lock Handle set (1U)
20	PH-PH #10-16 x 1/2" SMS. AISI 316 (4U)
21	PH-PH #10-16 x 1" Self Drilling. AISI 410 (8U)

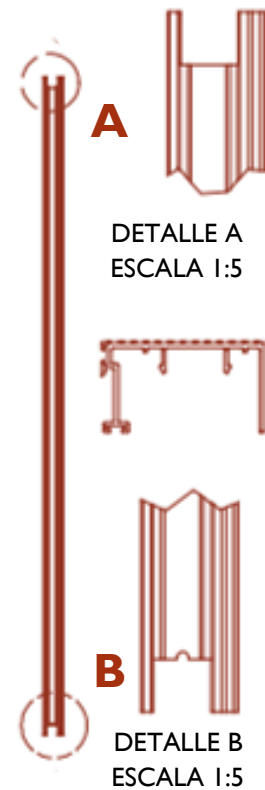

XO AND OX APLICACIÓN DE SILICONE INSTRUCCIONES

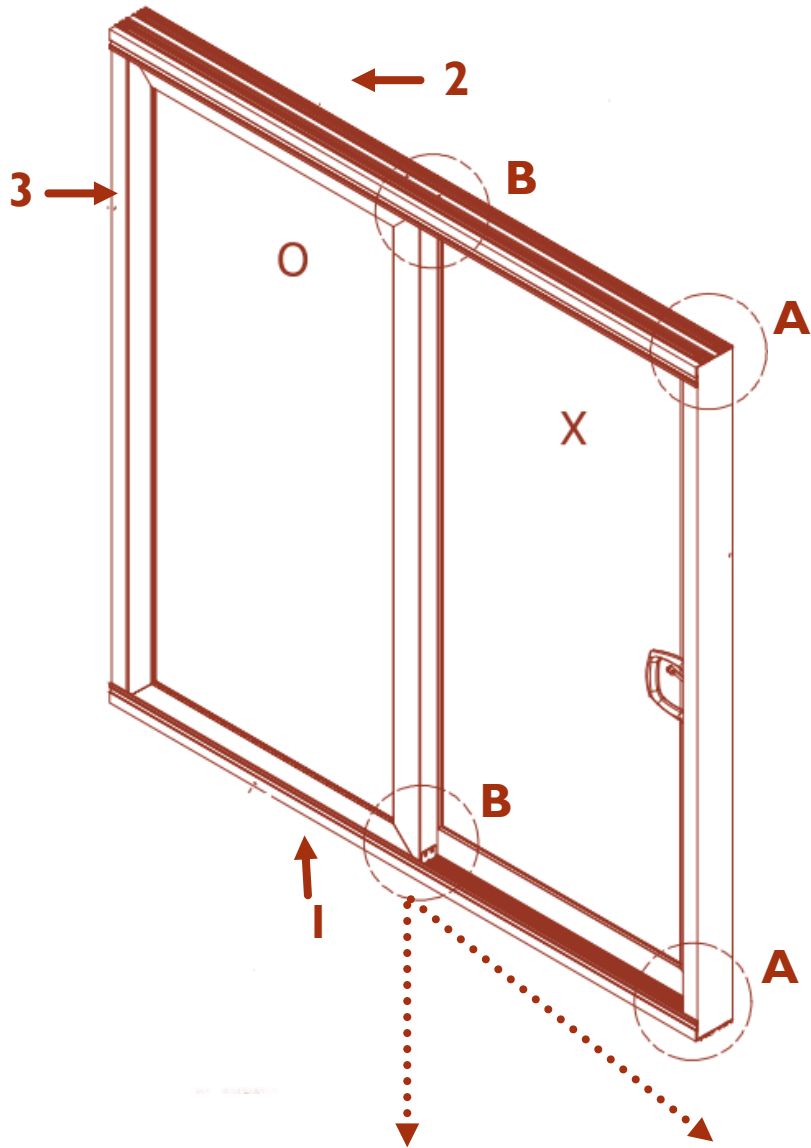

# Parte	Descripción
1	Sill (1U)
	Head (1U)
3	Jambs (2U)
4	Hex Head #12 x 1 1/2" SMS. AISI 410 (16U)
5	Track Short (1U)
6	Track Long (1U)
7	Flat Cover Long (1U)
8	Flat Cover Short (1U)
9	Vertical Cover (2U)
10	Horizontal Cover (2U)
11	Air Seal Bridge (2U)
12	Panels (2U)
13	Bumper (1U)
14	PH-FH #10-16 x 3/4" SMS, AISI 316 (16U)
15	Roller Adjust Hole Plug (4U)
16	Bottom Panel Guide (2U)
17	Top Panel Guide (2U)
18	Striker (1U)
19	Lock Handle set (1U)
20	PH-PH #10-16 x 1/2" SMS. AISI 316 (4U)
21	PH-PH #10-16 x 1" Self Drilling. AISI 410 (8U)

APLICAR SILICONA PARA ENCUBRIR EL WEATHERSTRIP CON EL LADO DE LA PUERTA & GASKET EN EL SILL

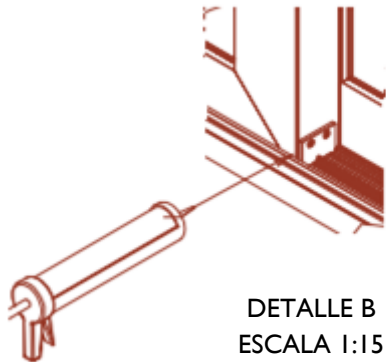

DETALLE B
ESCALA 1:15

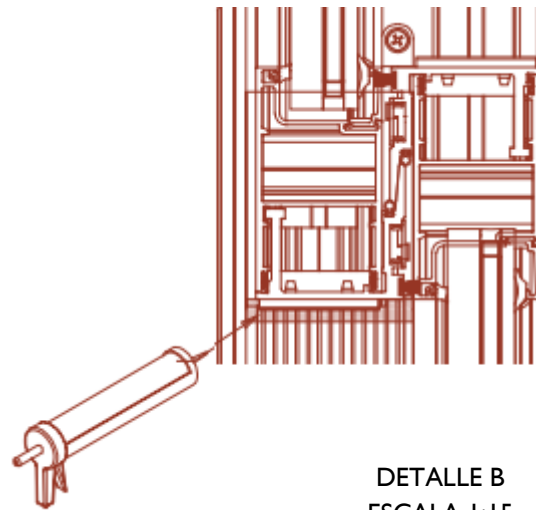

DETALLE B
ESCALA 1:15

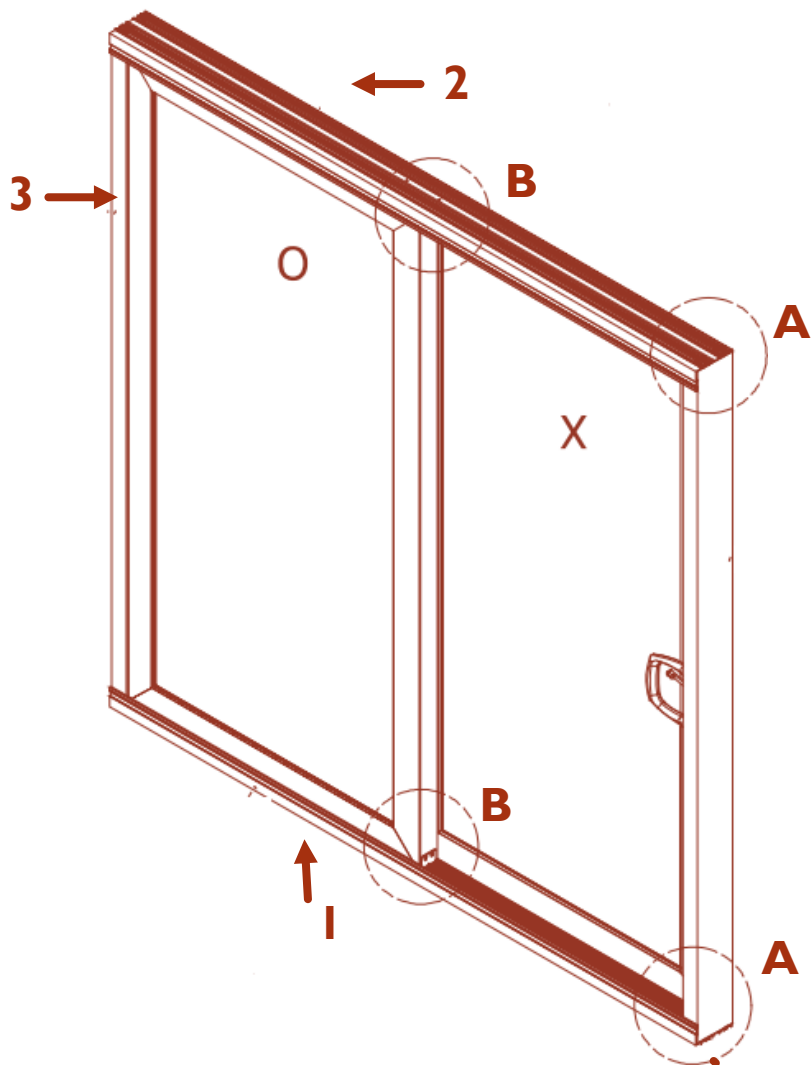

# Parte	Descripción
1	Sill (1U)
	Head (1U)
3	Jamb (2U)
4	Hex Head #12 x 1 1/2" SMS. AISI 410 (16U)
5	Track Short (1U)
6	Track Long (1U)
7	Flat Cover Long (1U)
8	Flat Cover Short (1U)
9	Vertical Cover (2U)
10	Horizontal Cover (2U)
11	Air Seal Bridge (2U)
12	Panels (2U)
13	Bumper (1U)
14	PH-FH #10-16 x 3/4" SMS, AISI 316 (16U)
15	Roller Adjust Hole Plug (4U)
16	Bottom Panel Guide (2U)
17	Top Panel Guide (2U)
18	Striker (1U)
19	Lock Handle set (1U)
20	PH-PH #10-16 x 1/2" SMS. AISI 316 (4U)
21	PH-PH #10-16 x 1" Self Drilling. AISI 410 (8U)

APLICAR SILICONA PARA ENCUBRIR EL WEATHERSTRIP CON EL LADO DE LA PUERTA & GASKET EN EL SILL

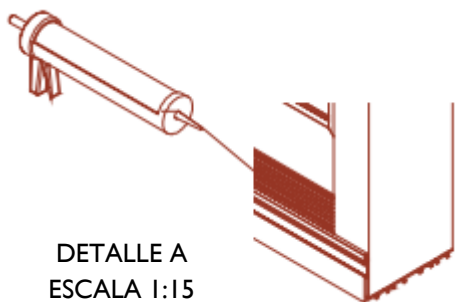

DETALLE A
ESCALA 1:15

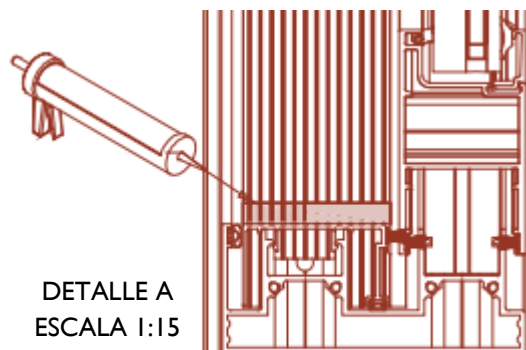

DETALLE A
ESCALA 1:15

XO AND OX INSTALACIÓN DE MANILLA INSTRUCCIONES

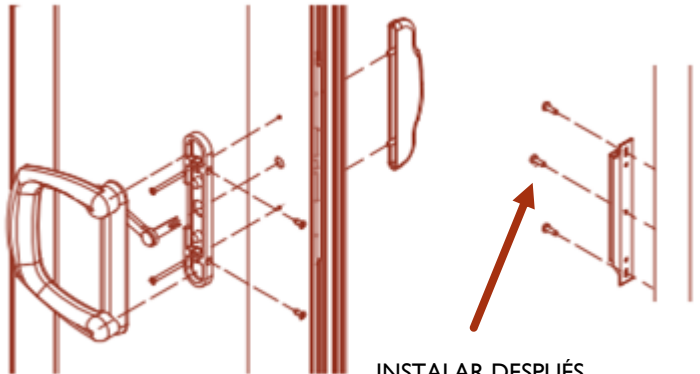

INSTALAR DESPUÉS
DE AJUSTAR CON
EL STRIKER

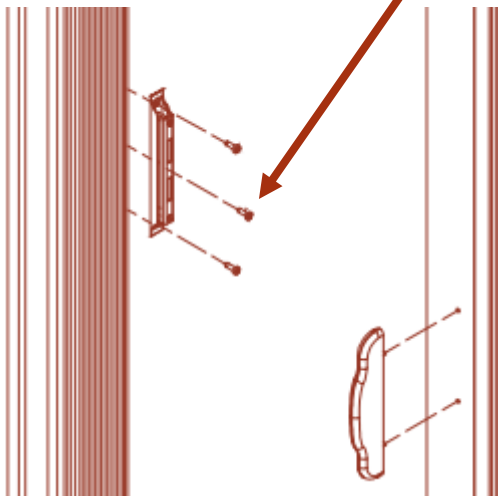

INSTALACIÓN DEL ROLLER AJUSTAR
EL PLUG Y LAS GUÍAS DE LOS
PANELES

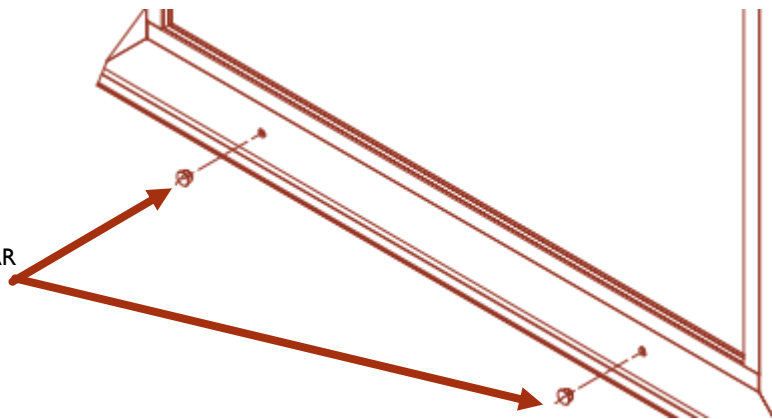





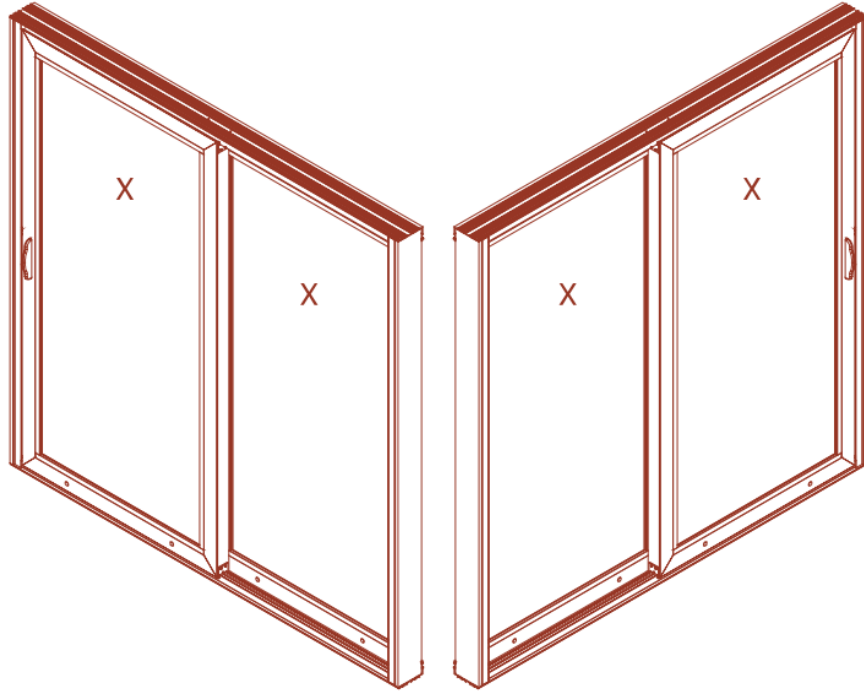



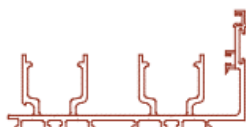
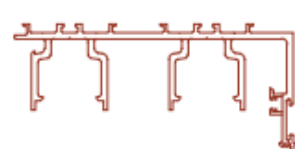

# Parte	Descripción
1	Sill (1U)
	Head (1U)
3	Jambs (2U)
4	Hex Head #12 x 1 1/2" SMS. AISI 410 (16U)
5	Track Short (1U)
6	Track Long (1U)
7	Flat Cover Long (1U)
8	Flat Cover Short (1U)
9	Vertical Cover (2U)
10	Horizontal Cover (2U)
11	Air Seal Bridge (2U)
12	Panels (2U)
13	Bumper (1U)
14	PH-FH #10-16 x 3/4" SMS. AISI 316 (16U)
15	Roller Adjust Hole Plug (4U)
16	Bottom Panel Guide (2U)
17	Top Panel Guide (2U)
18	Striker (1U)
19	Lock Handle set (1U)
20	PH-PH #10-16 x 1/2" SMS. AISI 316 (4U)
21	PH-PH #10-16 x 1" Self Drilling. AISI 410 (8U)



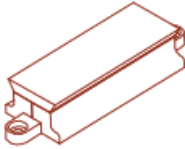

XX PAQUETE

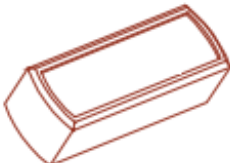

PARA LA CONFIGURACIÓN XX VER PAGINAS 89-92
 PARA LA SELECCIÓN DE TIPO DE PANEL

# Parte	Descripción	Imagen
1	Sill (1U)	
2	Head (1U)	
3	Jambs (2U)	
4	Hex Head #12 x 1 1/2" SMS. AISI 410 (16U)	

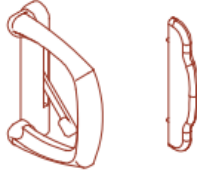
5	Track Long (1U)	
6	Flat Cover Long (1U)	
7	Vertical Cover (2U)	
8	Air Seal Bridge (2U)	
9	Panels (2U)	
10	Bumper (2U)	
11	PH-FH #10-16 x 3/4' SMS, AISI 316 (16U)	
12	Roller Adjust Hole Plug (4U)	

13	Bottom Panel Guide (2U)	
14	Top Panel Guide (2U)	
15	Striker (2U)	
16	Lock Handle set (1U)	
17	PH-PH #10-16 x 1" Self Drilling. AISI 410 (12U)	
18	PH-PH #10-16 x 1/2" SMS. AISI 316 (4U)	

XX TRACK INSTRUCCIONES

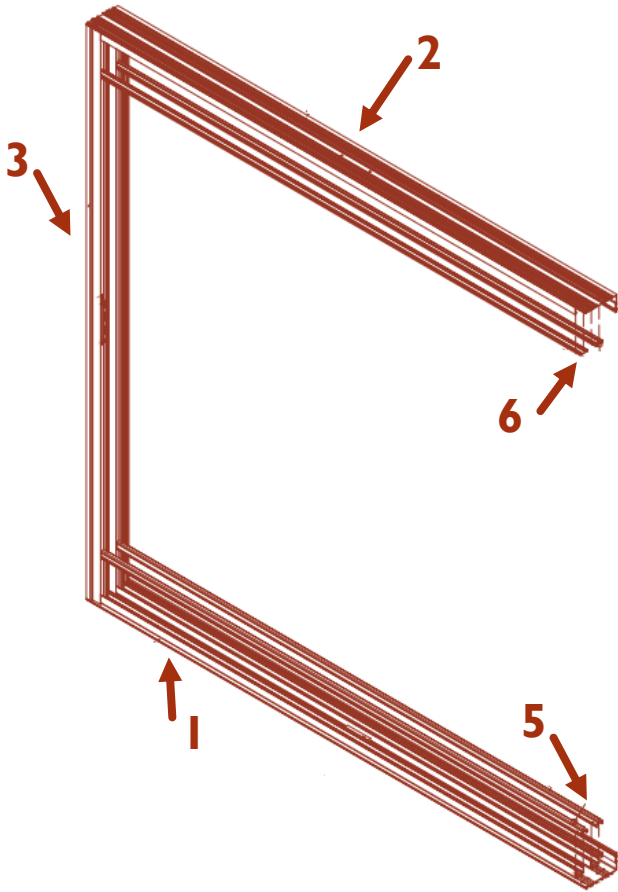

# Parte	Descripción
1	Sill (1U)
2	Head (1U)
3	Jambs (2U)
4	Hex Head #12 x 1 1/2" SMS, AISI 410 (16U)
5	Track Long (1U)
6	Flat Cover Long (1U)
7	Vertical Cover (2U)
8	Air Seal Bridge (2U)
9	Panels (2U)
10	Bumper (2U)
11	PH-FH #10-16 x 3/4" SMS, AISI 316 (16U)
12	Roller Adjust Hole Plug (4U)
13	Bottom Panel Guide (2U)
14	Top Panel Guide (2U)
15	Striker (2U)
16	Lock Handle set (1U)
17	PH-PH #10-16 x 1" Self Drilling, AISI 410 (12U)
18	PH-PH #10-16 x 1/2" SMS, AISI 316 (4U)

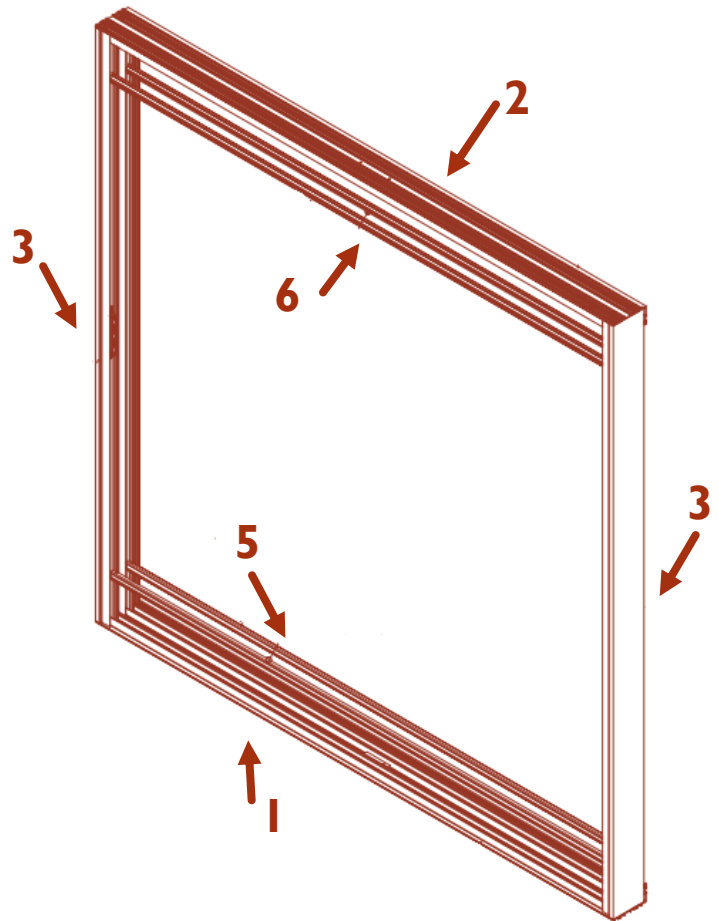

XX PANEL INSTRUCCIONES

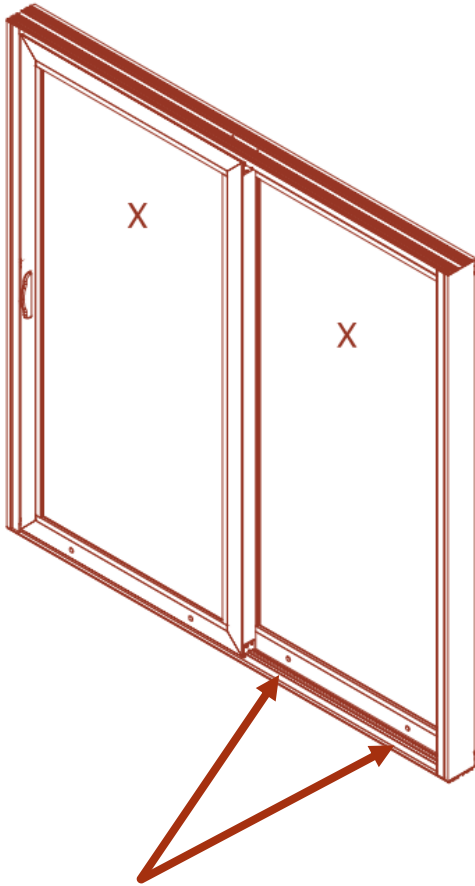

HUECOS DE AJUSTE EN LA PARTE INFERIOR

# Parte	Descripción
1	Sill (1U)
2	Head (1U)
3	Jambs (2U)
4	Hex Head #12 x 1 1/2" SMS, AISI 410 (16U)
5	Track Long (1U)
6	Flat Cover Long (1U)
7	Vertical Cover (2U)
8	Air Seal Bridge (2U)
9	Panels (2U)
10	Bumper (2U)
11	PH-FH #10-16 x 3/4" SMS, AISI 316 (16U)
12	Roller Adjust Hole Plug (4U)
13	Bottom Panel Guide (2U)
14	Top Panel Guide (2U)
15	Striker (2U)
16	Lock Handle set (1U)
17	PH-PH #10-16 x 1" Self Drilling, AISI 410 (12U)
18	PH-PH #10-16 x 1/2" SMS, AISI 316 (4U)

POSICION DE EL AIR SEAL BRIDGE EN EL SILL & HEAD. NO PUEDE ESTAR EN LA POSICION FINAL DURANTE LA INSTALACION DE LOS PANELES

POSICION DE LOS PANELES

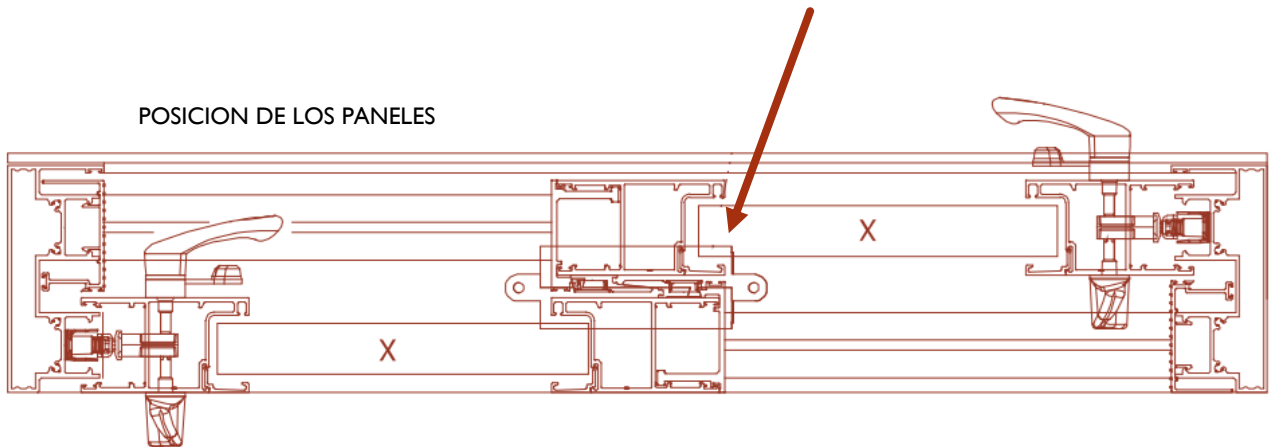

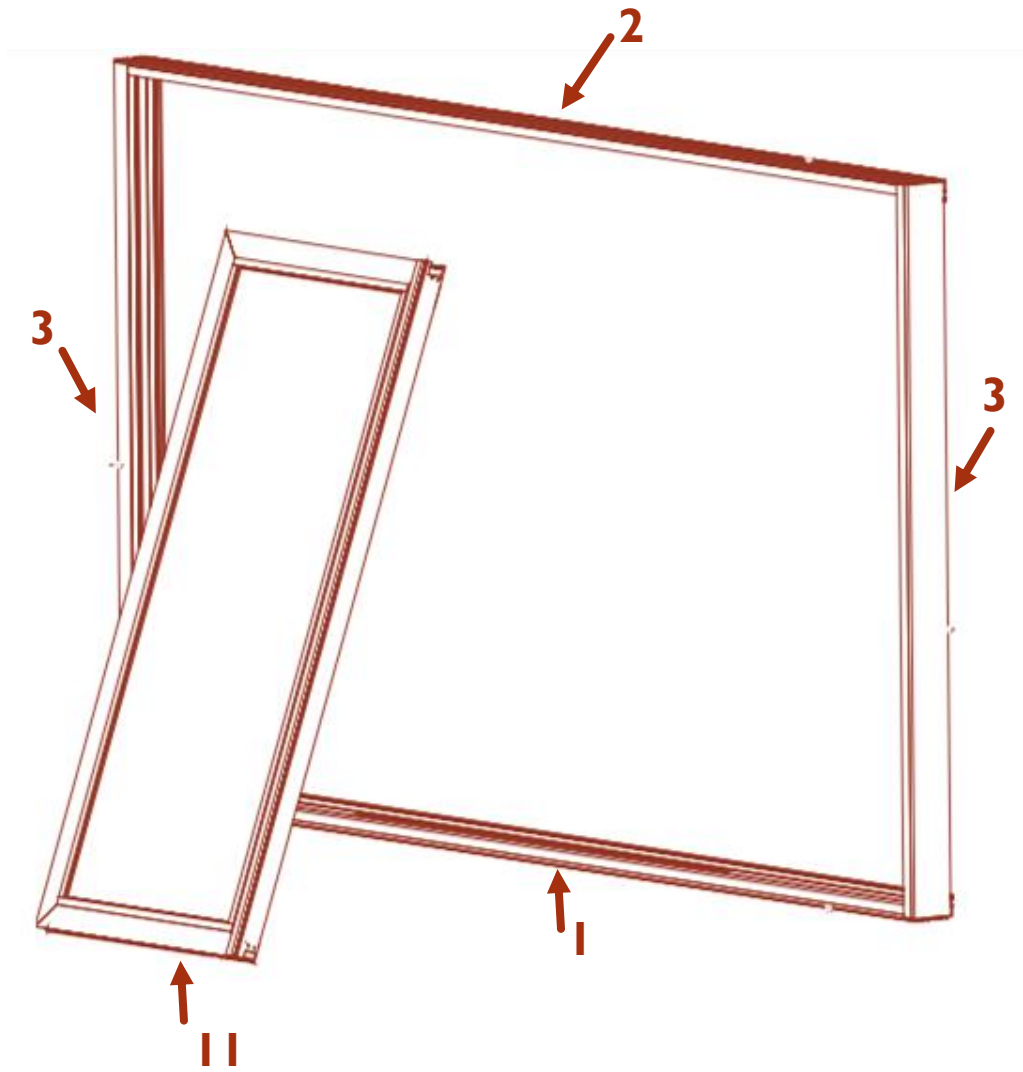

NOTA: TODOS LOS PANELES SON INSTALADOS DE LA MISMA MANERA
PARA LA POSICIÓN DE LOS PANELES DE LA CONFIGURACIÓN XX, VER
PÁGINA **TIPO DE PANELES**

XX COVERS INSTRUCCIONES

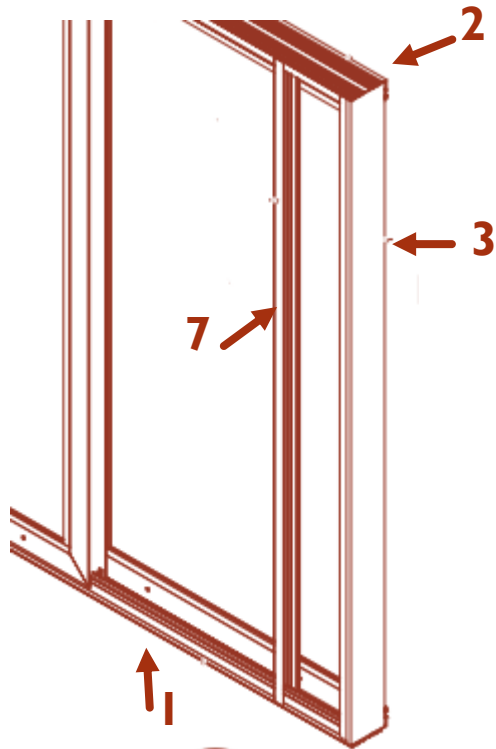

# Parte	Descripción
1	Sill (1U)
2	Head (1U)
3	Jambs (2U)
4	Hex Head #12 x 1 1/2" SMS, AISI 410 (16U)
5	Track Long (1U)
6	Flat Cover Long (1U)
7	Vertical Cover (2U)
8	Air Seal Bridge (2U)
9	Panels (2U)
10	Bumper (2U)
11	PH-FH #10-16 x 3/4" SMS, AISI 316 (16U)
12	Roller Adjust Hole Plug (4U)
13	Bottom Panel Guide (2U)
14	Top Panel Guide (2U)
15	Striker (2U)
16	Lock Handle set (1U)
17	PH-PH #10-16 x 1" Self Drilling, AISI 410 (12U)
18	PH-PH #10-16 x 1/2" SMS, AISI 316 (4U)

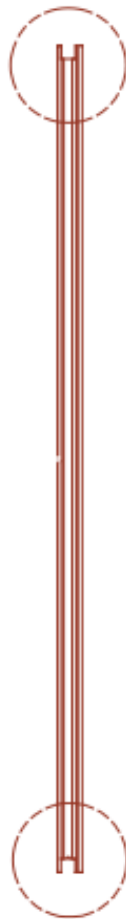

B



DETALLE B
ESCALA 1:4

A

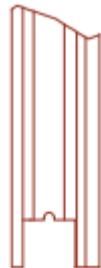

DETALLE B
ESCALA 1:4

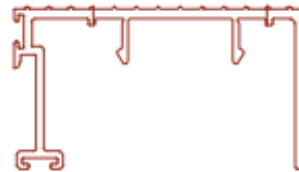

XX MANILLA INSTRUCCIONES

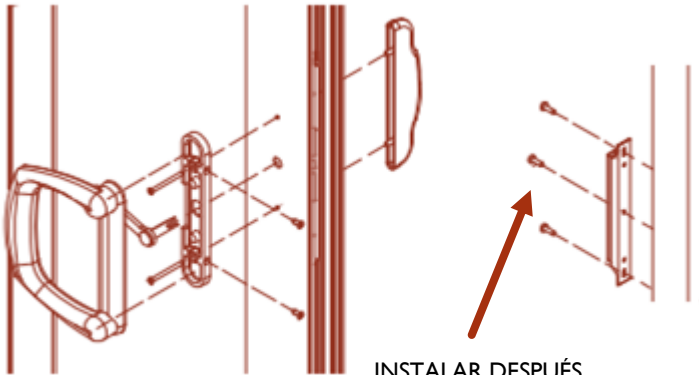

INSTALAR DESPUÉS
DE AJUSTAR CON
EL STRIKER

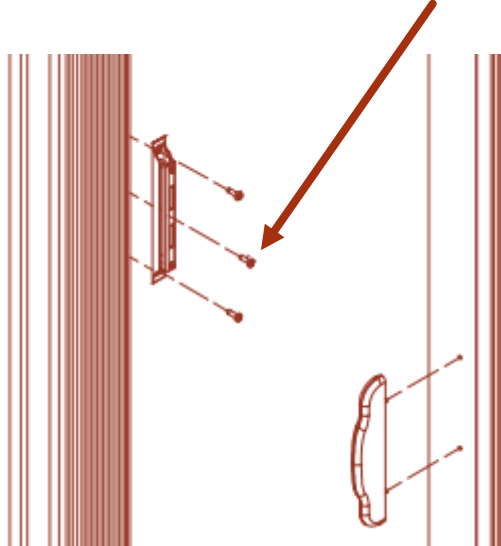

INSTALACIÓN DEL ROLLER AJUSTAR
EL PLUG Y LAS GUÍAS DE LOS
PANELES

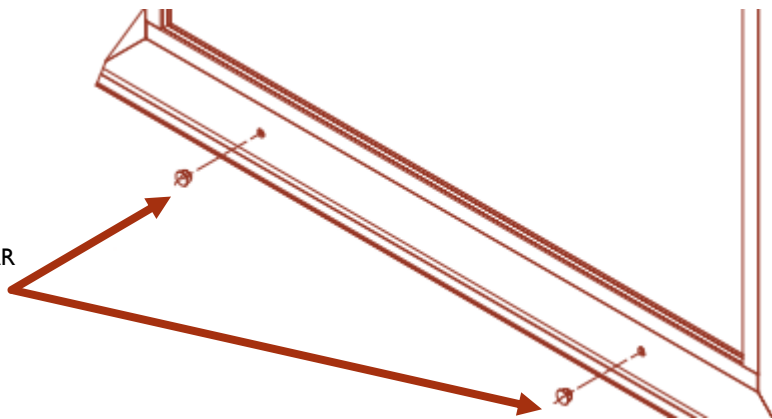





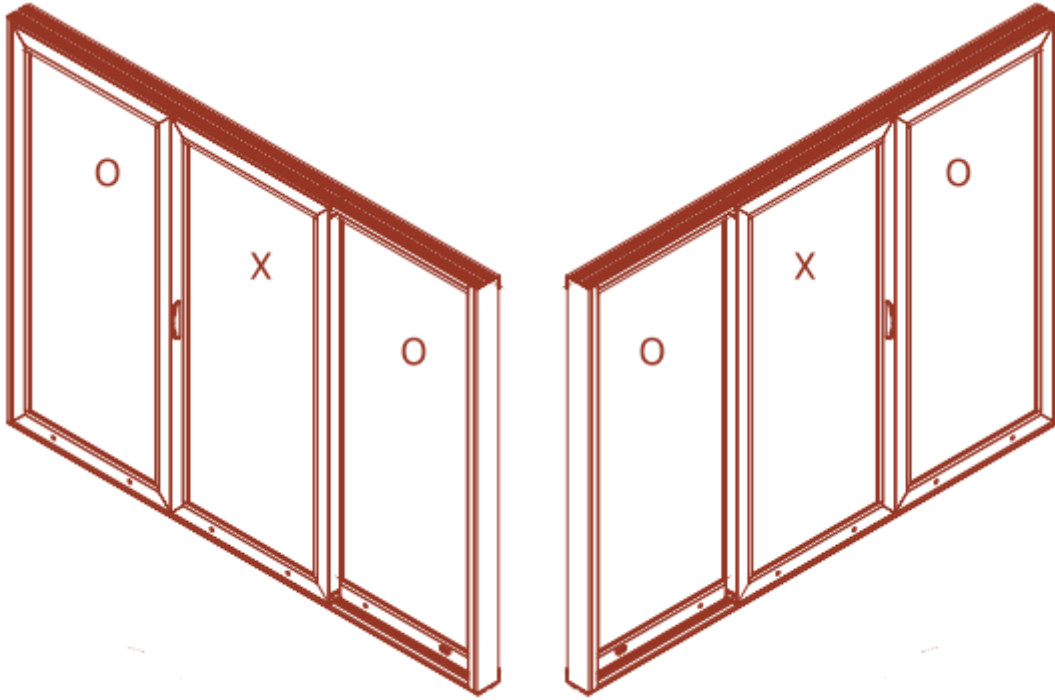

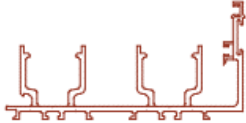
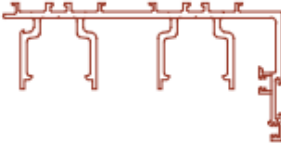

# Parte	Descripción
1	Sill (1U)
2	Head (1U)
3	Jambs (2U)
4	Hex Head #12 x 1 1/2" SMS, AISI 410 (16U)
5	Track Long (1U)
6	Flat Cover Long (1U)
7	Vertical Cover (2U)
8	Air Seal Bridge (2U)
9	Panels (2U)
10	Bumper (2U)
11	PH-FH #10-16 x 3/4" SMS, AISI 316 (16U)
12	Roller Adjust Hole Plug (4U)
13	Bottom Panel Guide (2U)
14	Top Panel Guide (2U)
15	Striker (2U)
16	Lock Handle set (1U)
17	PH-PH #10-16 x 1" Self Drilling, AISI 410 (12U)
18	PH-PH #10-16 x 1/2" SMS, AISI 316 (4U)







OXO PARTES

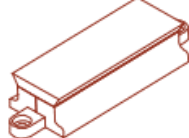

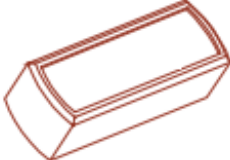



PARA LA CONFIGURACIÓN XX VER PAGINAS 89-92
PARA LA SELECCIÓN DE TIPO DE PANEL

# Parte	Descripción	Imagen
1	Sill (1U)	
2	Head (1U)	
3	Jambs (2U)	

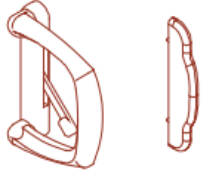
4	Hex Head #12 x 1 1/2" SMS. AISI 410 (16U)	
5	Track Short (1U)	
6	Track Long (1U)	
7	Flat Cover Long (1U)	
8	Flat Cover Short (1U)	
9	Vertical Cover (2U)	
10	Horizontal Cover (2U)	
11	Air Seal Bridge (4U)	

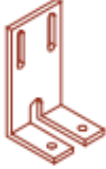
12	Panels (3U)	
13	Bumper (2U)	
14	PH-FH #10-16 x 3/4" SMS, AISI 316 (20U)	
15	Roller Adjust Hole Plug (6U)	
16	Bottom Panel Guide (4U)	
17	Top Panel Guide (4U)	
18	Striker (1U)	

19	Lock Handle set (1U)	
20	PH-PH #10-16 x 1" Self Drilling. AISI 410 (15U)	
21	Fix Panel Attachment (2U)	
22	PH-PH #10-16 x 1/2" SMS. AISI 316 (4U)	

OXO TRACK INSTRUCCIONES

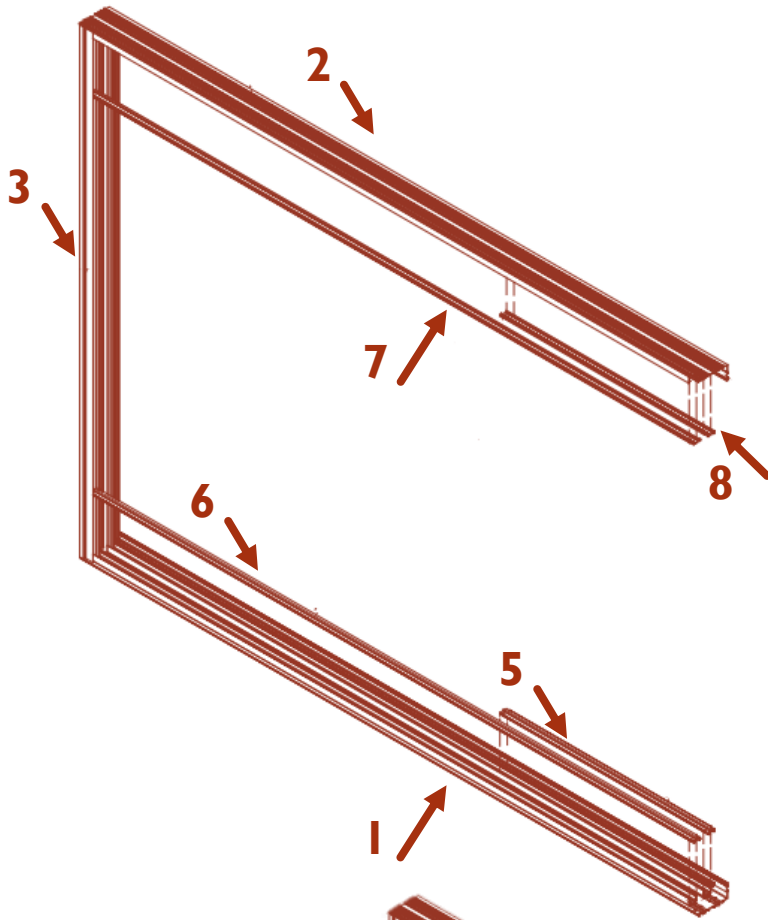

# Parte	Descripción
1	Sill (1U)
2	Head (1U)
3	Jambs (2U)
4	Hex Head #12 x 1 1/2" SMS, AISI 410 (16U)
5	Track Short (1U)
6	Track Long (1U)
7	Flat Cover Long (1U)
8	Flat Cover Short (1U)
9	Vertical Cover (2U)
10	Horizontal Cover (2U)
11	Air Seal Bridge (4U)
12	Panels (3U)
13	Bumper (2U)
14	PH-FH #10-16 x 3/4" SMS, AISI 316 (20U)
15	Roller Adjust Hole Plug (6U)
16	Bottom Panel Guide (4U)
17	Top Panel Guide (4U)
18	Striker (1U)
19	Lock Handle set (1U)
20	PH-PH #10-16 x 1" Self Drilling, AISI 410 (15U)
21	Fix Panel Attachment (2U)
22	PH-PH #10-16 x 1/2" SMS, AISI 316 (4U)

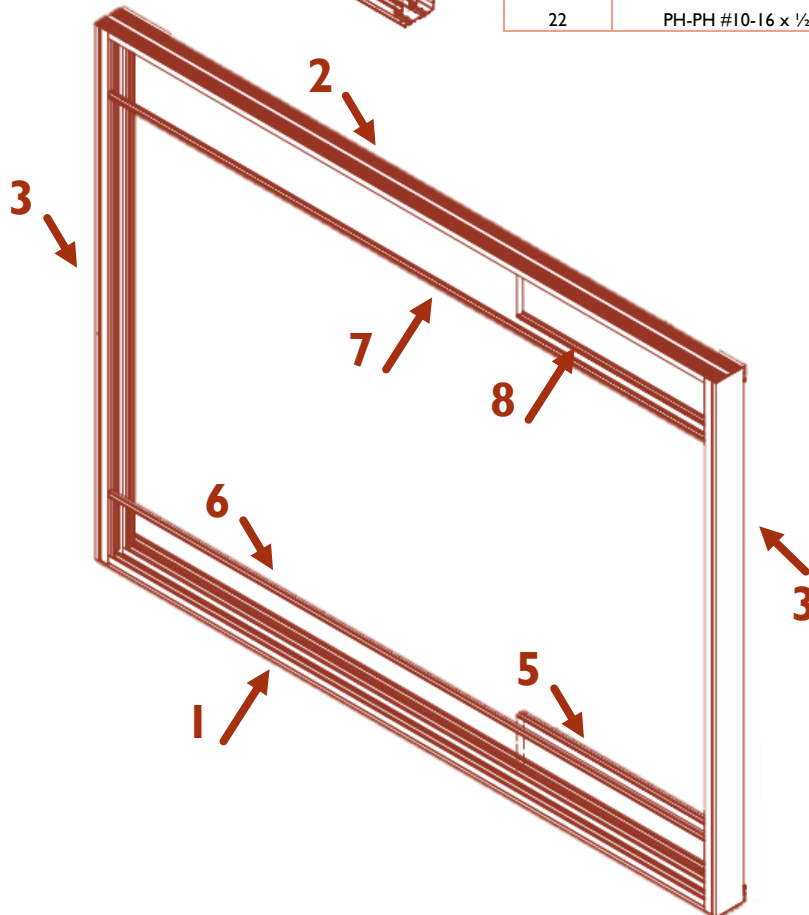

OXO PANELES INSTRUCCIONES

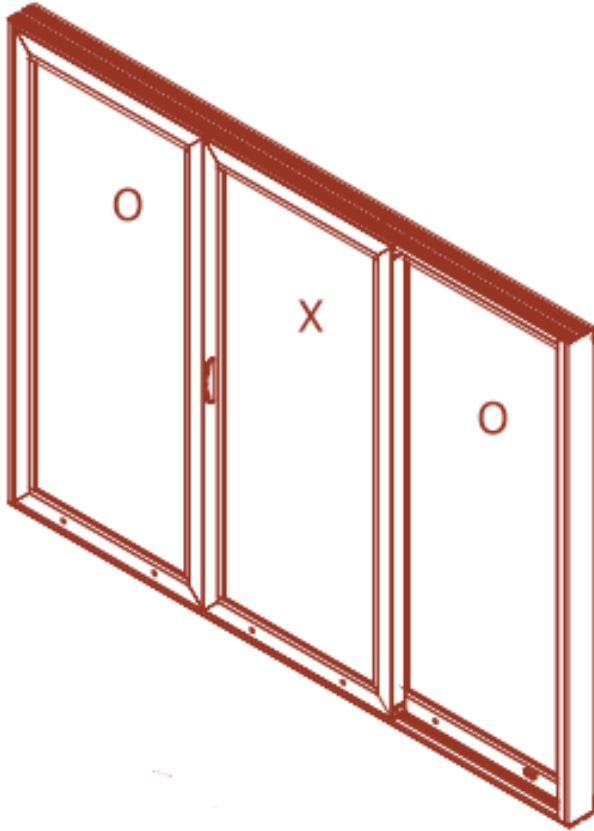

# Parte	Descripción
1	Sill (1U)
2	Head (1U)
3	Jamsb (2U)
4	Hex Head #12 x 1 1/2" SMS, AISI 410 (16U)
5	Track Short (1U)
6	Track Long (1U)
7	Flat Cover Long (1U)
8	Flat Cover Short (1U)
9	Vertical Cover (2U)
10	Horizontal Cover (2U)
11	Air Seal Bridge (4U)
12	Panels (3U)
13	Bumper (2U)
14	PH-FH #10-16 x 3/4" SMS, AISI 316 (20U)
15	Roller Adjust Hole Plug (6U)
16	Bottom Panel Guide (4U)
17	Top Panel Guide (4U)
18	Striker (1U)
19	Lock Handle set (1U)
20	PH-PH #10-16 x 1" Self Drilling, AISI 410 (15U)
21	Fix Panel Attachment (2U)
22	PH-PH #10-16 x 1/2" SMS, AISI 316 (4U)

POSICION DE EL AIR SEAL BRIDGE EN EL SILL & HEAD. NO PUEDE ESTAR EN LA POSICION FINAL DURANTE LA INSTALACION DE LOS PANELES

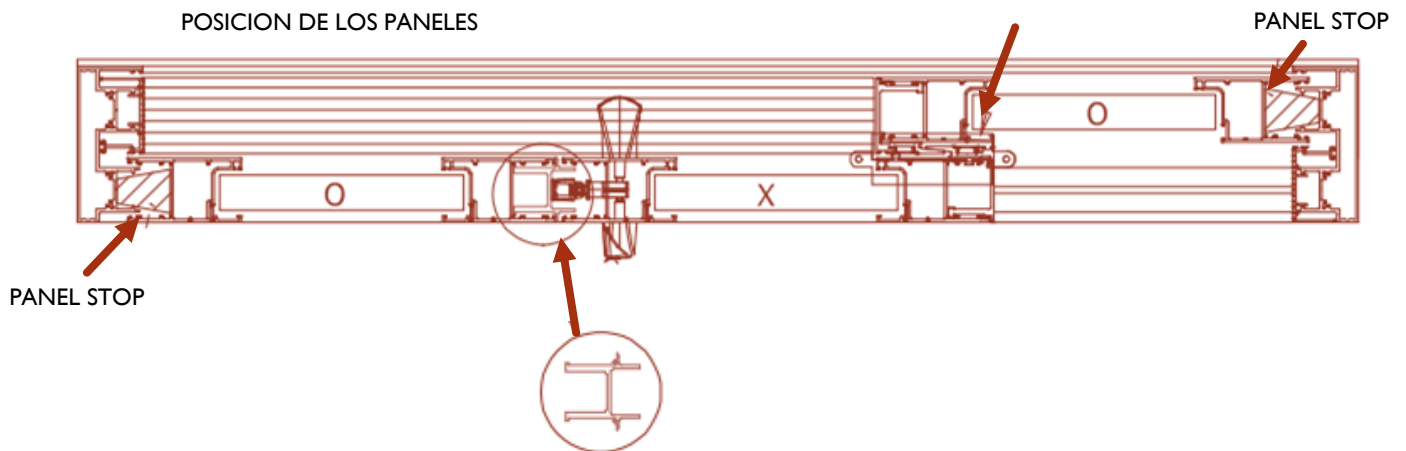

REMOVER QUITANDO LOS TRONILLOS PARA INSTALACION DEL PANEL & REINSTALAR DESPUES QUE ESTE SE ENCUENTRE EN LA POSICION FINAL & LOS ACCESORIOS #21 ESTAN EN SU LUGAR



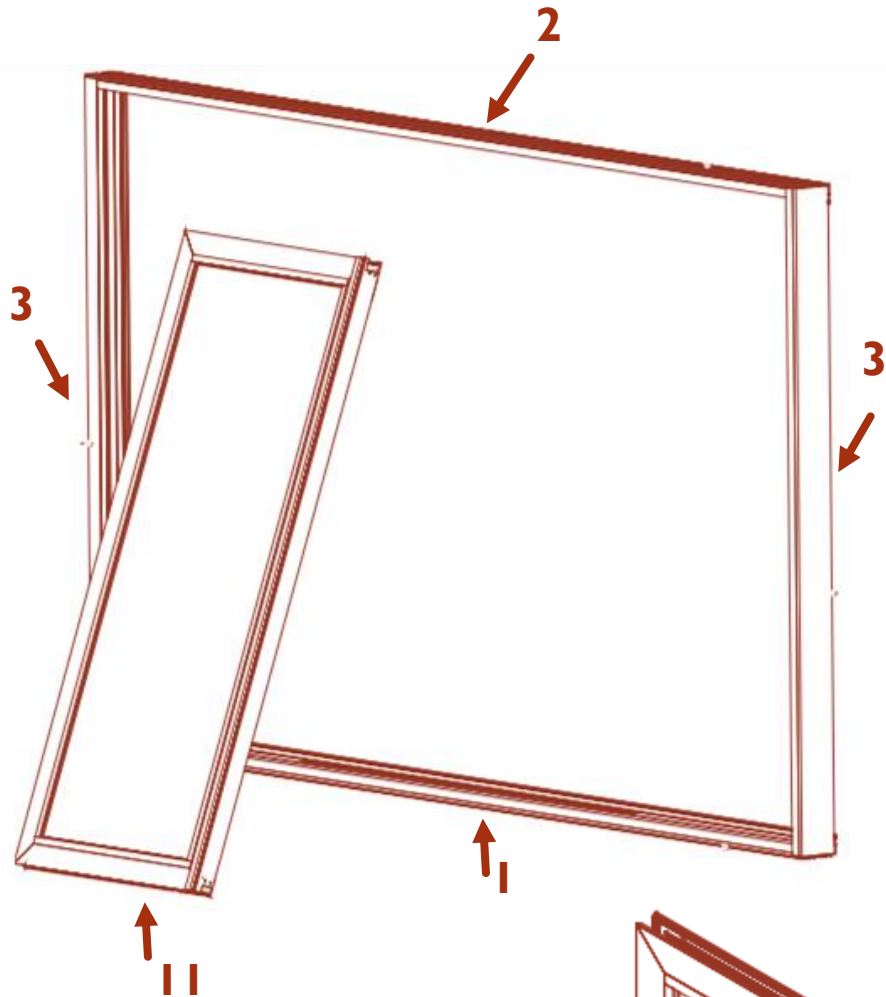

NOTA: TODOS LOS PANELES SON INSTALADOS DE LA MISMA MANERA

PARA LA POSICIÓN DE LOS PANELES DE LA CONFIGURACIÓN XX, VER PÁGINA **TIPO DE PANELES**

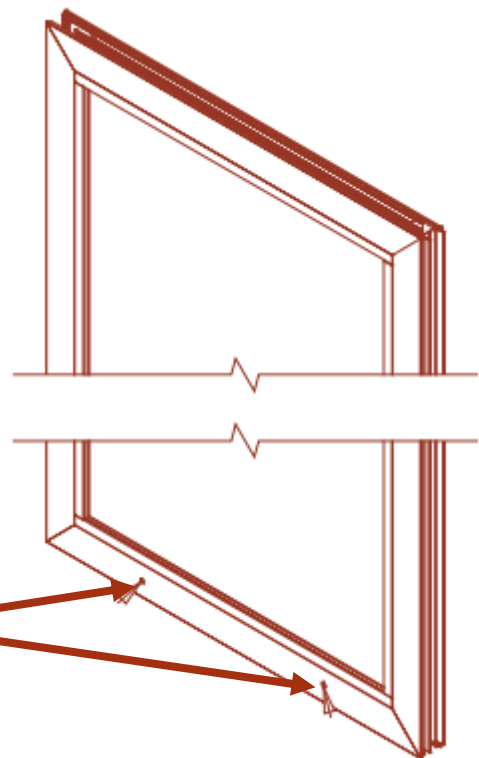

OXO PANEL FIJO INSTRUCCIONES

21

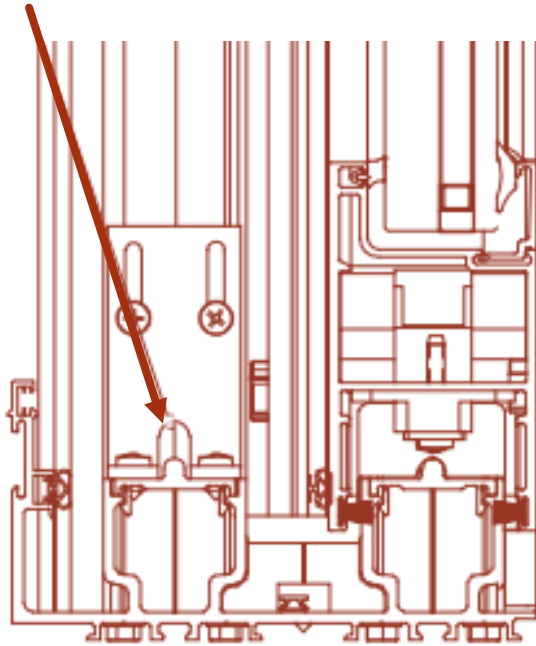

DETALLE A
ESCALA 1:3

# Parte	Descripción
1	Sill (1U)
2	Head (1U)
3	Jams (2U)
4	Hex Head #12 x 1 1/2" SMS, AISI 410 (16U)
5	Track Short (1U)
6	Track Long (1U)
7	Flat Cover Long (1U)
8	Flat Cover Short (1U)
9	Vertical Cover (2U)
10	Horizontal Cover (2U)
11	Air Seal Bridge (4U)
12	Panels (3U)
13	Bumper (2U)
14	PH-FH #10-16 x 3/4" SMS, AISI 316 (20U)
15	Roller Adjust Hole Plug (6U)
16	Bottom Panel Guide (4U)
17	Top Panel Guide (4U)
18	Striker (1U)
19	Lock Handle set (1U)
20	PH-PH #10-16 x 1" Self Drilling, AISI 410 (15U)
21	Fix Panel Attachment (2U)
22	PH-PH #10-16 x 1/2" SMS, AISI 316 (4U)

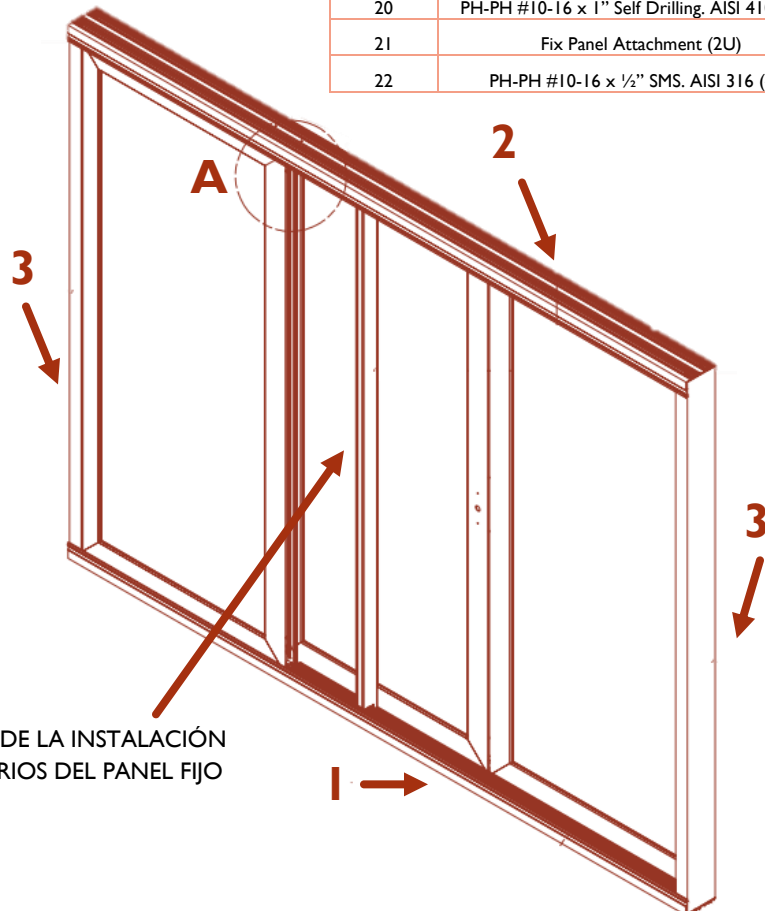

MOVER DESPUÉS DE LA INSTALACIÓN
DE LOS ACCESORIOS DEL PANEL FIJO



OXO PANEL FIJO ENCAJE

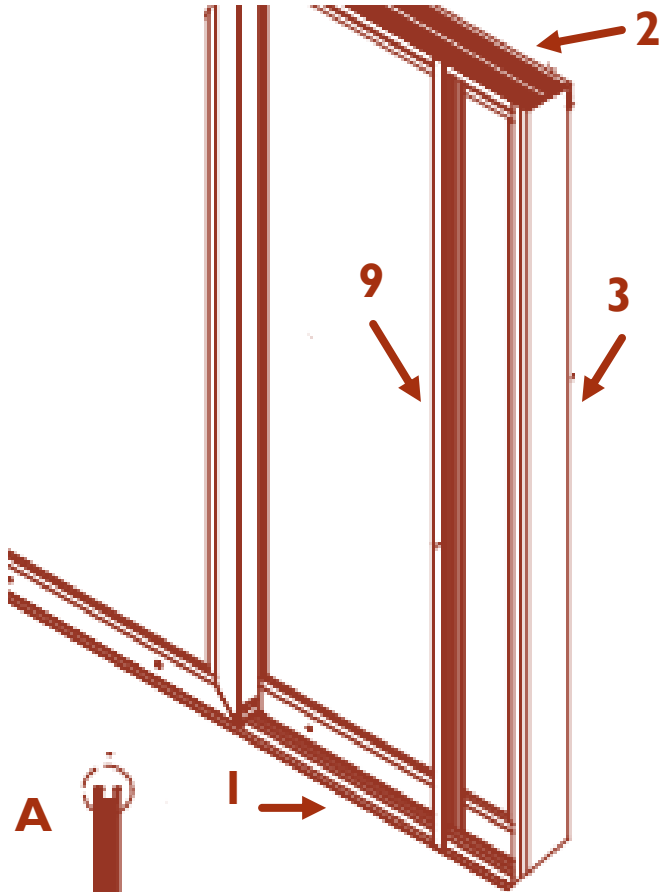

# Parte	Descripción
1	Sill (1U)
2	Head (1U)
3	Jambs (2U)
4	Hex Head #12 x 1 1/2" SMS, AISI 410 (16U)
5	Track Short (1U)
6	Track Long (1U)
7	Flat Cover Long (1U)
8	Flat Cover Short (1U)
9	Vertical Cover (2U)
10	Horizontal Cover (2U)
11	Air Seal Bridge (4U)
12	Panels (3U)
13	Bumper (2U)
14	PH-FH #10-16 x 3/4" SMS, AISI 316 (20U)
15	Roller Adjust Hole Plug (6U)
16	Bottom Panel Guide (4U)
17	Top Panel Guide (4U)
18	Striker (1U)
19	Lock Handle set (1U)
20	PH-PH #10-16 x 1" Self Drilling, AISI 410 (15U)
21	Fix Panel Attachment (2U)
22	PH-PH #10-16 x 1/2" SMS, AISI 316 (4U)

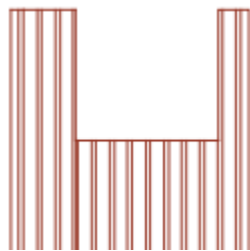
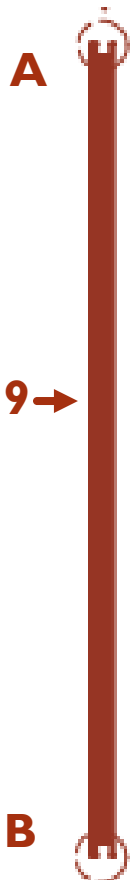

DETALLE A
ESCALA 1:3

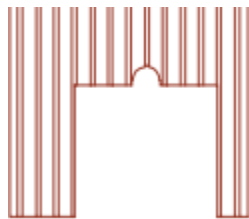

DETALLE B
ESCALA 1:3

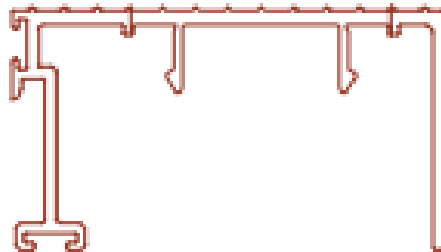

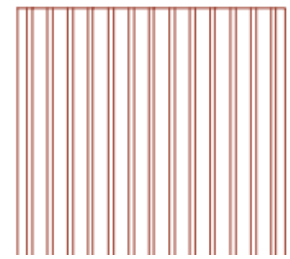
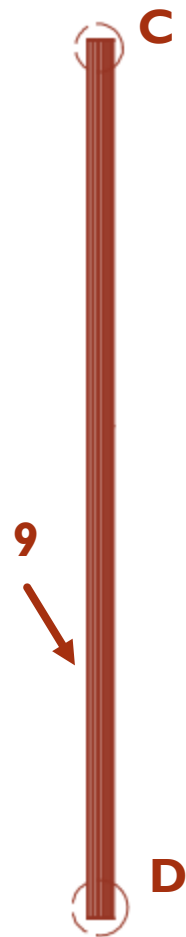
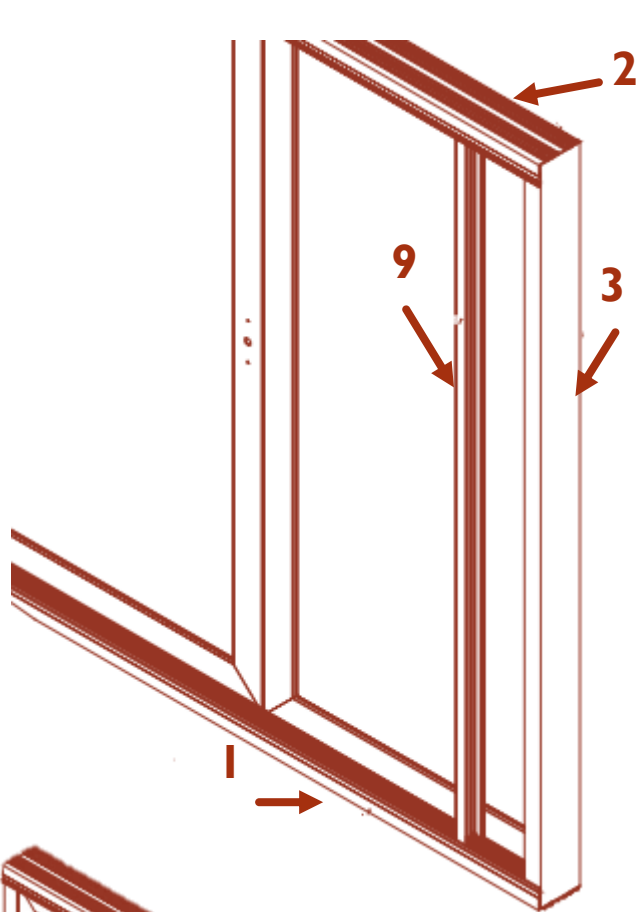

DETALLE C
ESCALA 1:3



DETALLE D
ESCALA 1:3

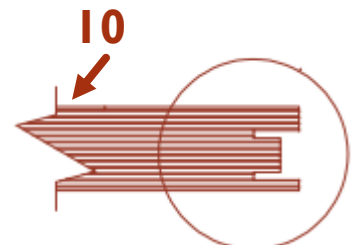
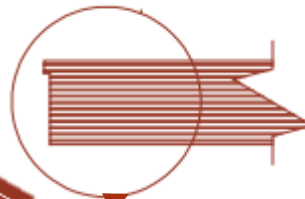
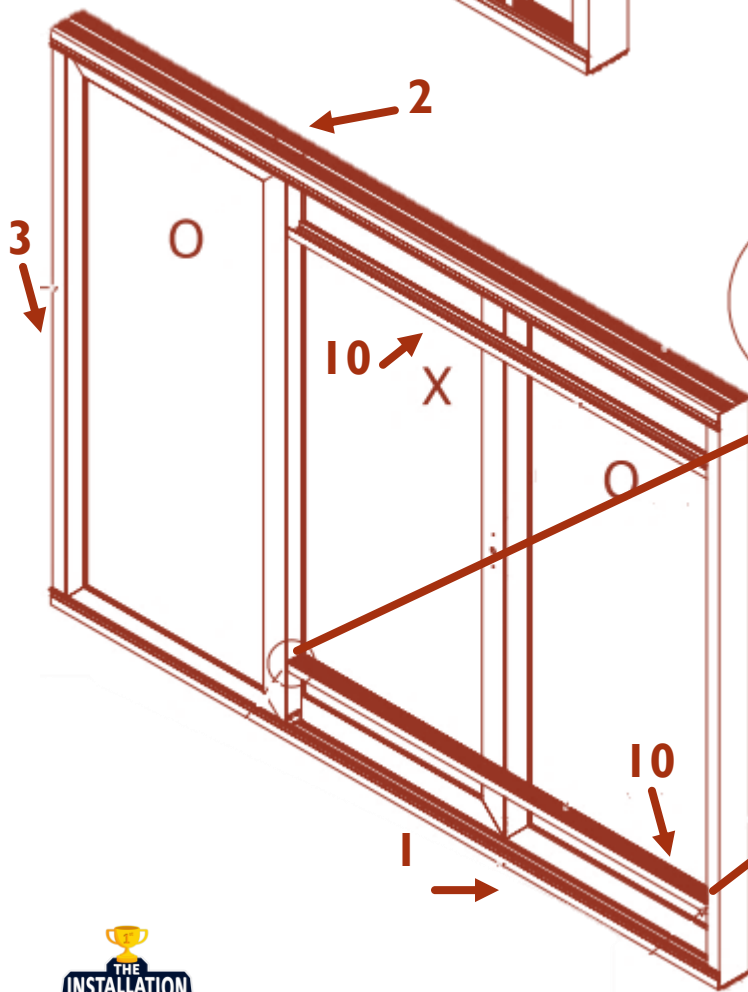

OXO APLICACIÓN DE SILICONE INSTRUCCIONES

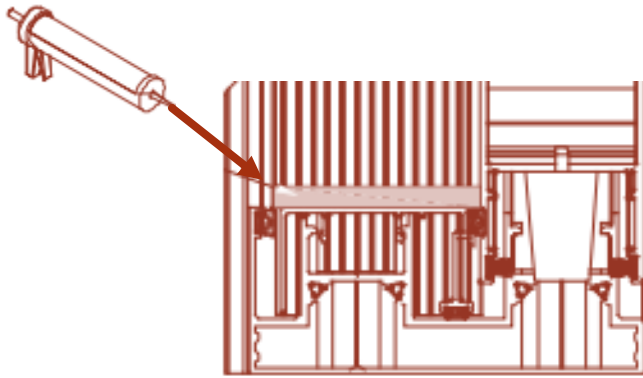

DETALLE A
ESCALA 1:3

# Parte	Descripción
1	Sill (1U)
2	Head (1U)
3	Jams (2U)
4	Hex Head #12 x 1 1/2" SMS, AISI 410 (16U)
5	Track Short (1U)
6	Track Long (1U)
7	Flat Cover Long (1U)
8	Flat Cover Short (1U)
9	Vertical Cover (2U)
10	Horizontal Cover (2U)
11	Air Seal Bridge (4U)
12	Panels (3U)
13	Bumper (2U)
14	PH-FH #10-16 x 3/4" SMS, AISI 316 (20U)
15	Roller Adjust Hole Plug (6U)
16	Bottom Panel Guide (4U)
17	Top Panel Guide (4U)
18	Striker (1U)
19	Lock Handle set (1U)
20	PH-PH #10-16 x 1" Self Drilling, AISI 410 (15U)
21	Fix Panel Attachment (2U)
22	PH-PH #10-16 x 1/2" SMS, AISI 316 (4U)

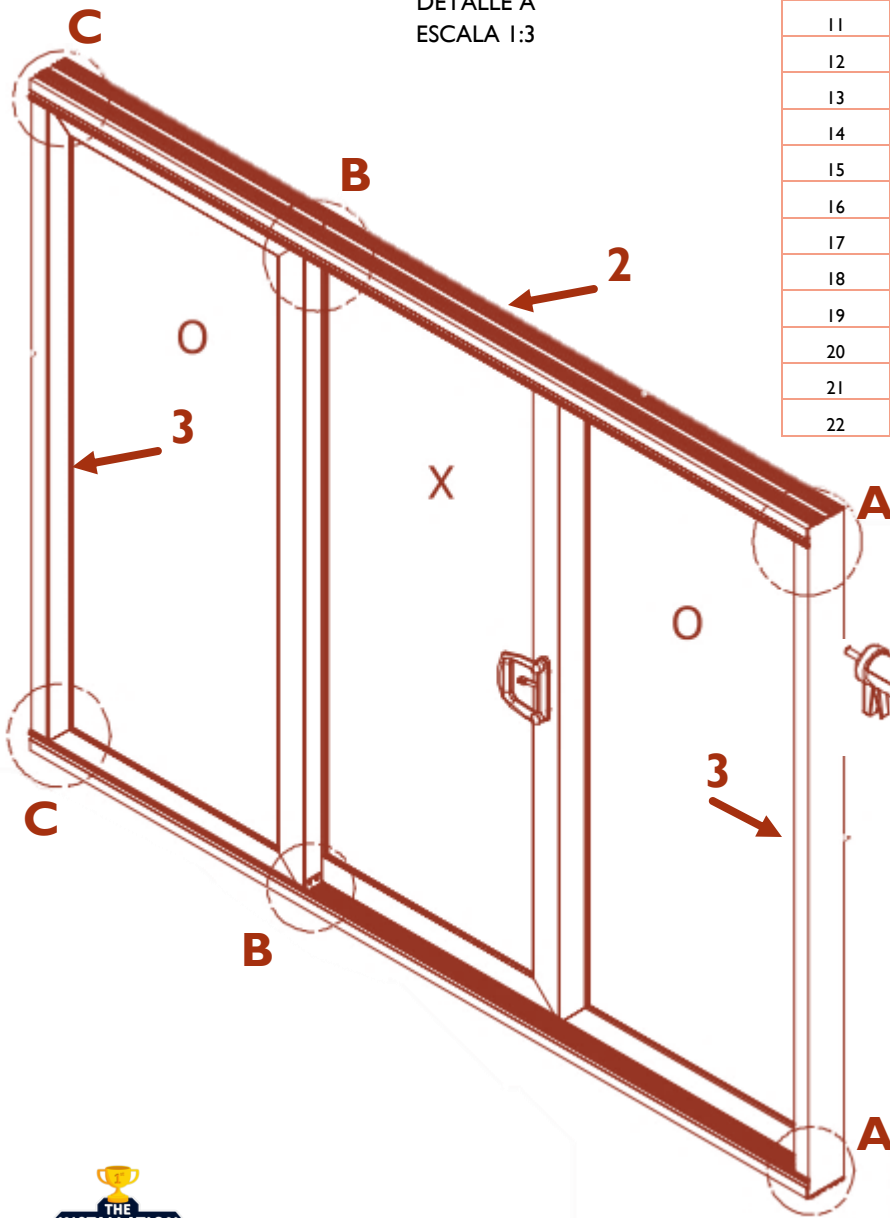

NOTA: APLICAR CLEAR SILICONA

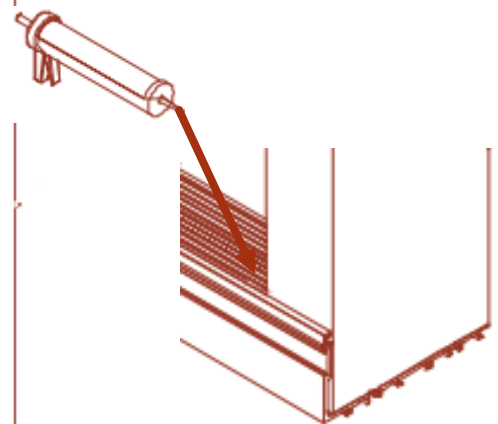

DETALLE A
ESCALA 1:5



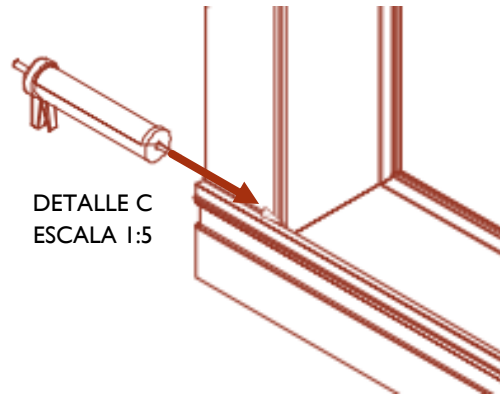

DETALLE C
ESCALA 1:5

APLICAR SILICONA PARA CUBRIR EL WEATHERSTRIP CON EL LADO DE LA PUERTA & GASKET EN EL SILL

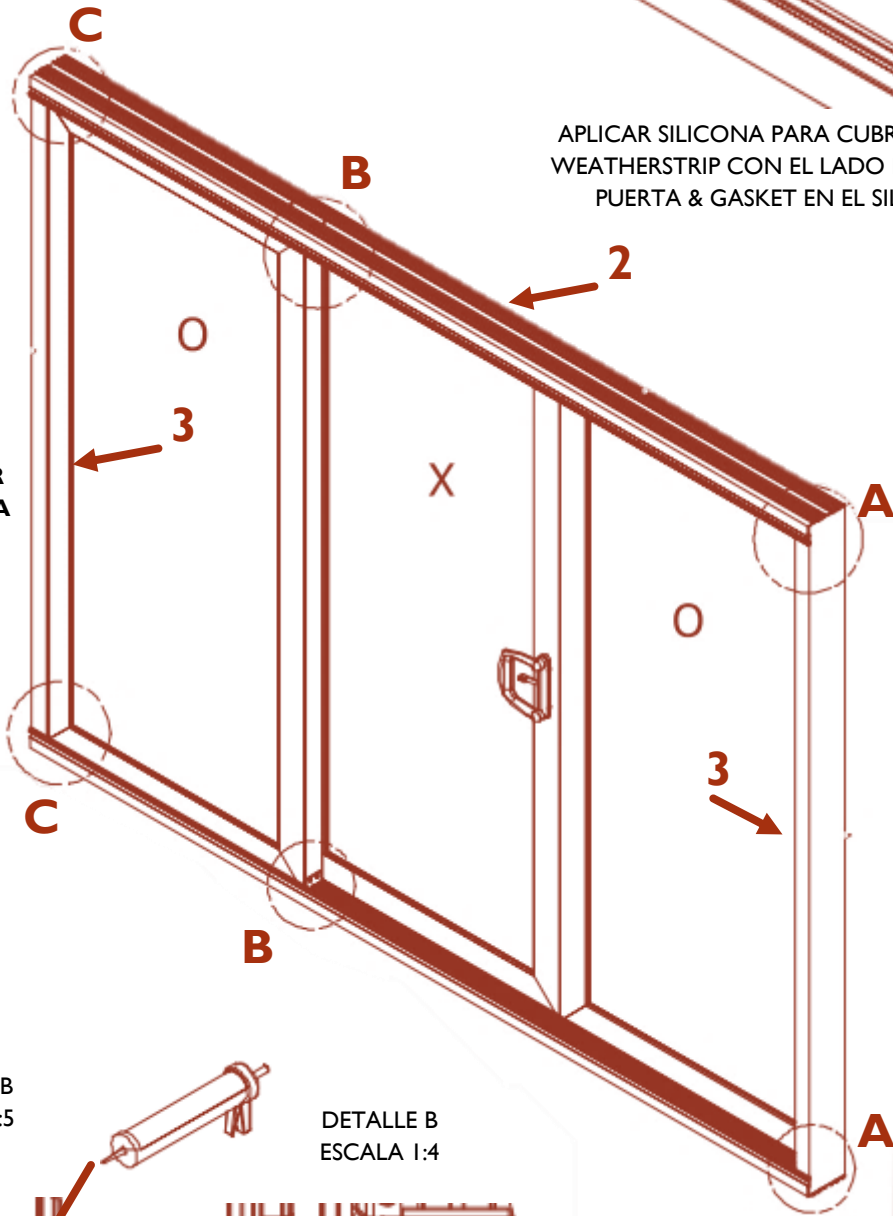

NOTA: APLICAR CLEAR SILICONA

DETALLE B
ESCALA 1:5

DETALLE B
ESCALA 1:4



APLICAR SILICONA PARA ENCUBRIR LA JUNTA VERTICAL, HORIZONTAL & EL COVER VERTICAL



OXO INSTALACIÓN DE MANILLA INSTRUCCIONES

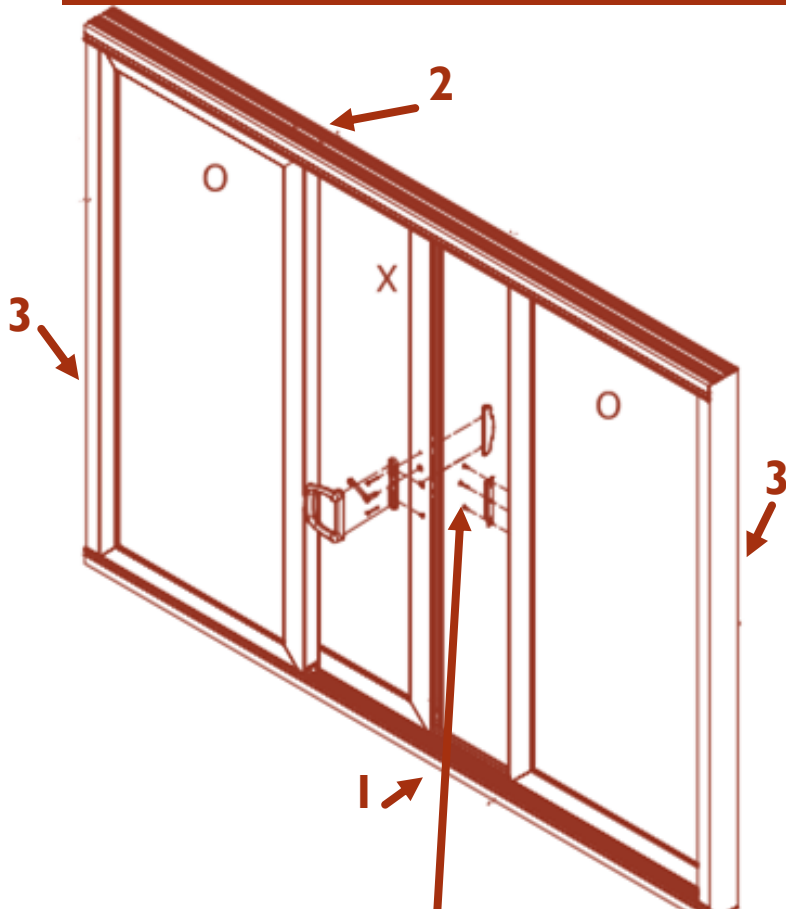

# Parte	Descripción
1	Sill (1U)
2	Head (1U)
3	Jambs (2U)
4	Hex Head #12 x 1 1/2" SMS, AISI 410 (16U)
5	Track Short (1U)
6	Track Long (1U)
7	Flat Cover Long (1U)
8	Flat Cover Short (1U)
9	Vertical Cover (2U)
10	Horizontal Cover (2U)
11	Air Seal Bridge (4U)
12	Panels (3U)
13	Bumper (2U)
14	PH-FH #10-16 x 3/4" SMS, AISI 316 (20U)
15	Roller Adjust Hole Plug (6U)
16	Bottom Panel Guide (4U)
17	Top Panel Guide (4U)
18	Striker (1U)
19	Lock Handle set (1U)
20	PH-PH #10-16 x 1" Self Drilling, AISI 410 (15U)
21	Fix Panel Attachment (2U)

INSTALAR DESPUÉS DE AJUSTAR EL STRIKER

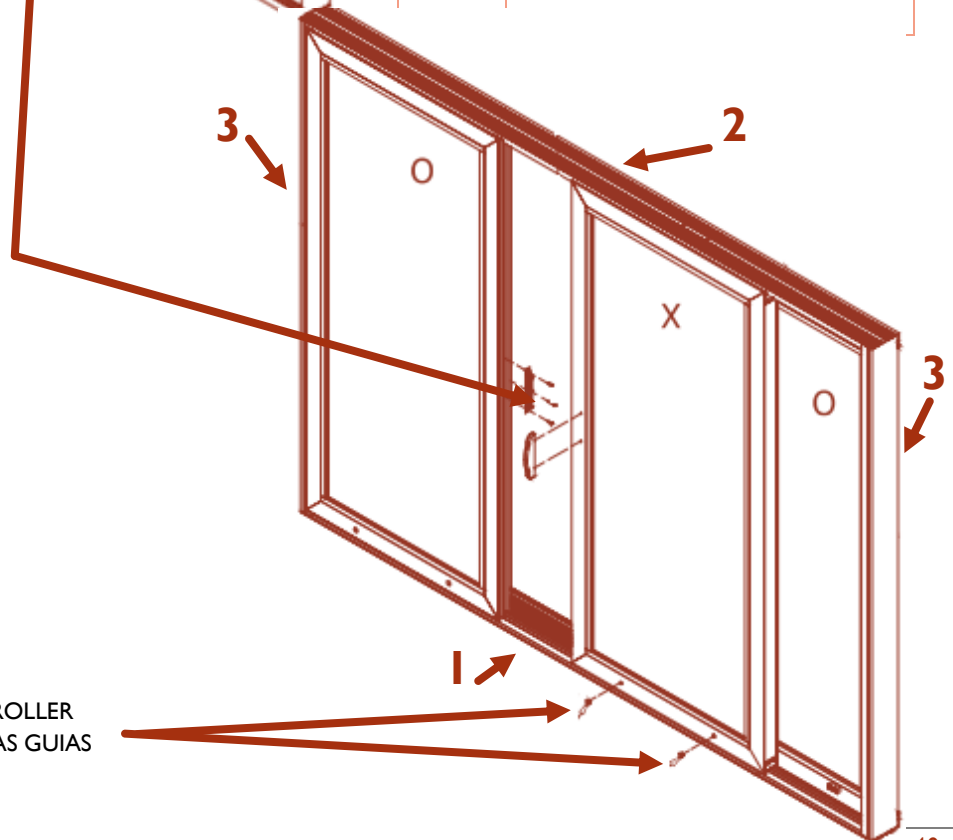



INSTALACIÓN DEL ROLLER AJUSTAR EL PLUG Y LAS GUIAS



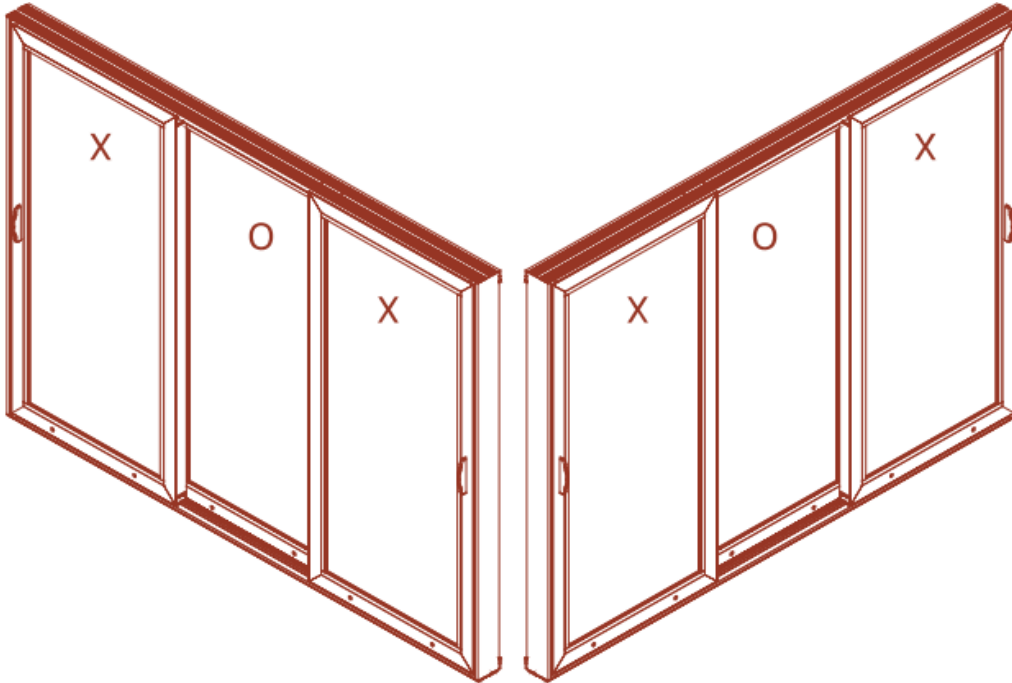



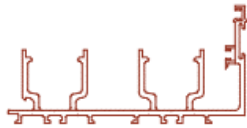
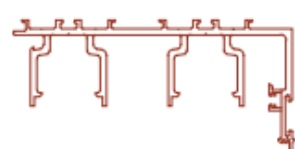







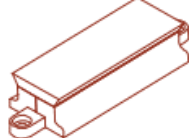

XOX PARTES



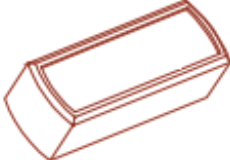



PARA LA CONFIGURACIÓN XOX VER PAGINAS 89-92 PARA LA SELECCIÓN DE TIPO DE PANEL

# Parte	Descripción	Imagen
1	Sill (1U)	
2	Head (1U)	
3	Jambs (2U)	

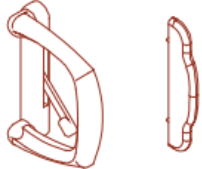
4	Hex Head #12 x 1 1/2" SMS. AISI 410 (16U)	
5	Track Short (1U)	
6	Track Long (1U)	
7	Flat Cover Long (1U)	
8	Flat Cover Short (1U)	
9	Vertical Cover (2U)	
10	Horizontal Cover (2U)	
11	Air Seal Bridge (4U)	

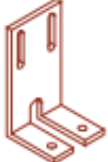
12	Panels (3U)	
13	Bumper (2U)	
14	PH-FH #10-16 x 3/4" SMS, AISI 316 (24U)	
15	Roller Adjust Hole Plug (6U)	
16	Bottom Panel Guide (4U)	
17	Top Panel Guide (4U)	
18	Striker (1U)	

19	Lock Handle set (1U)	
20	PH-PH #10-16 x 1" Self Drilling. AISI 410 (14U)	
21	Fix Panel Attachment (2U)	
22	PH-PH #10-16 x 1/2" SMS. AISI 316 (8U)	

XOX TRACK INSTRUCCIONES

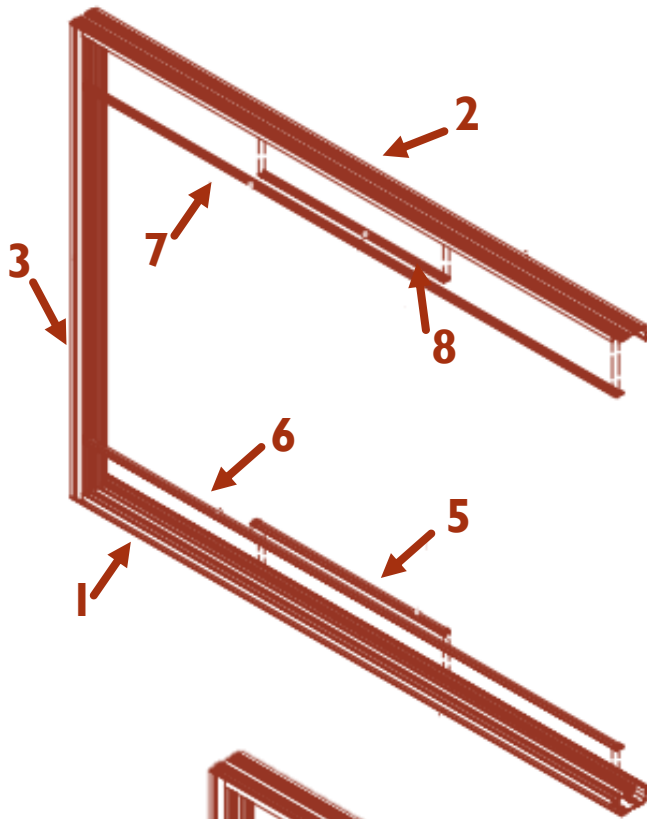

# Parte	Descripción
1	Sill (1U)
2	Head (1U)
3	Jambs (2U)
4	Hex Head #12 x 1 1/2" SMS. AISI 410 (16U)
5	Track Short (1U)
6	Track Long (1U)
7	Flat Cover Long (1U)
8	Flat Cover Short (1U)
9	Vertical Cover (2U)
10	Horizontal Cover (2U)
11	Air Seal Bridge (4U)
12	Panels (3U)
13	Bumper (2U)
14	PH-FH #10-16 x 3/4" SMS, AISI 316 (24U)
15	Roller Adjust Hole Plug (6U)
16	Bottom Panel Guide (4U)
17	Top Panel Guide (4U)
18	Striker (1U)
19	Lock Handle set (1U)
20	PH-PH #10-16 x 1" Self Drilling. AISI 410 (14U)
21	Fix Panel Attachment (2U)
22	PH-PH #10-16 x 1/2" SMS. AISI 316 (8U)

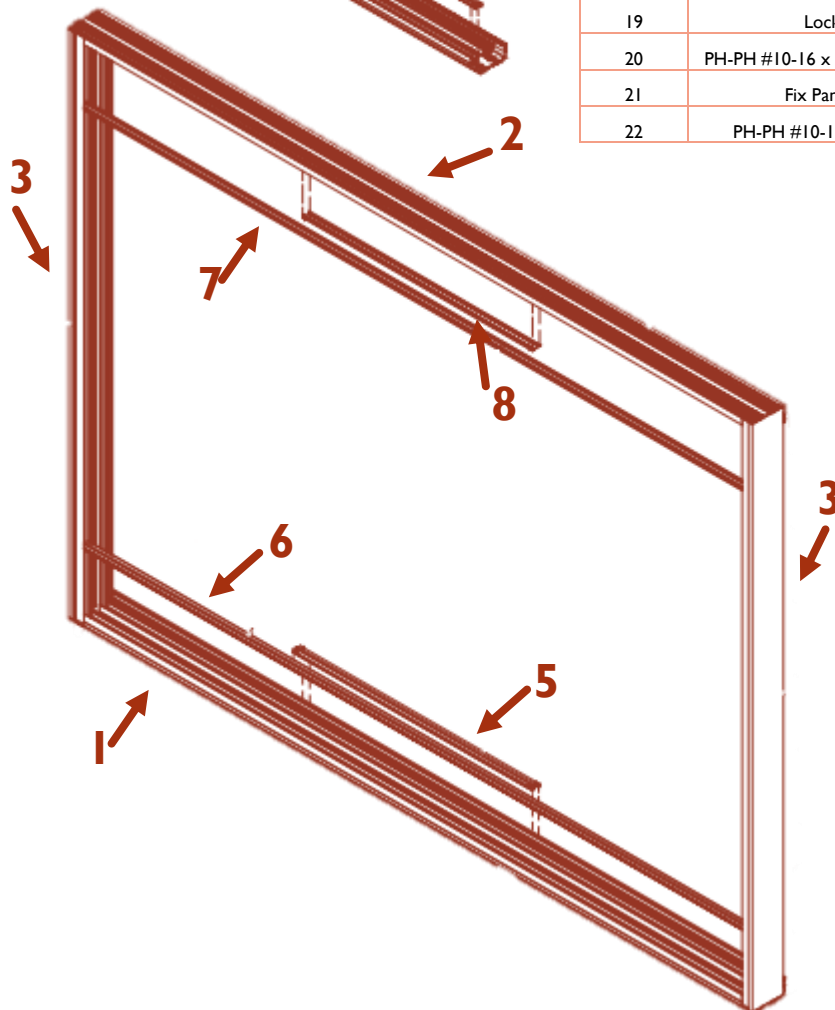

XOX PANELS INSTRUCCIONES

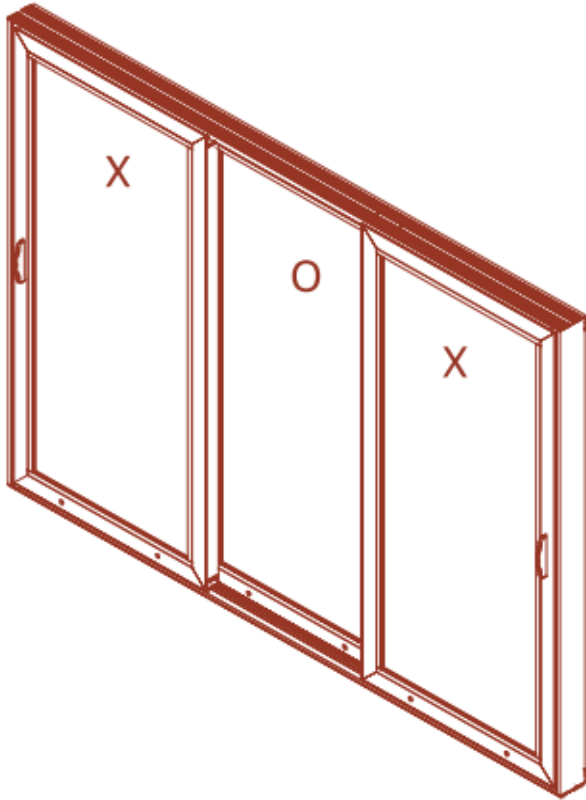

# Parte	Descripción
1	Sill (1U)
2	Head (1U)
3	Jambs (2U)
4	Hex Head #12 x 1 1/2" SMS. AISI 410 (16U)
5	Track Short (1U)
6	Track Long (1U)
7	Flat Cover Long (1U)
8	Flat Cover Short (1U)
9	Vertical Cover (2U)
10	Horizontal Cover (2U)
11	Air Seal Bridge (4U)
12	Panels (3U)
13	Bumper (2U)
14	PH-FH #10-16 x 3/4" SMS, AISI 316 (24U)
15	Roller Adjust Hole Plug (6U)
16	Bottom Panel Guide (4U)
17	Top Panel Guide (4U)
18	Striker (1U)
19	Lock Handle set (1U)
20	PH-PH #10-16 x 1" Self Drilling. AISI 410 (14U)
21	Fix Panel Attachment (2U)
22	PH-PH #10-16 x 1/2" SMS. AISI 316 (8U)

POSICIÓN DE EL AIR SEAL BRIDGE EN EL SILL & HEAD. NO PUEDE ESTAR EN LA POSICIÓN FINAL DURANTE LA INSTALACIÓN DE LOS PANELES

POSICIÓN DE PANELES

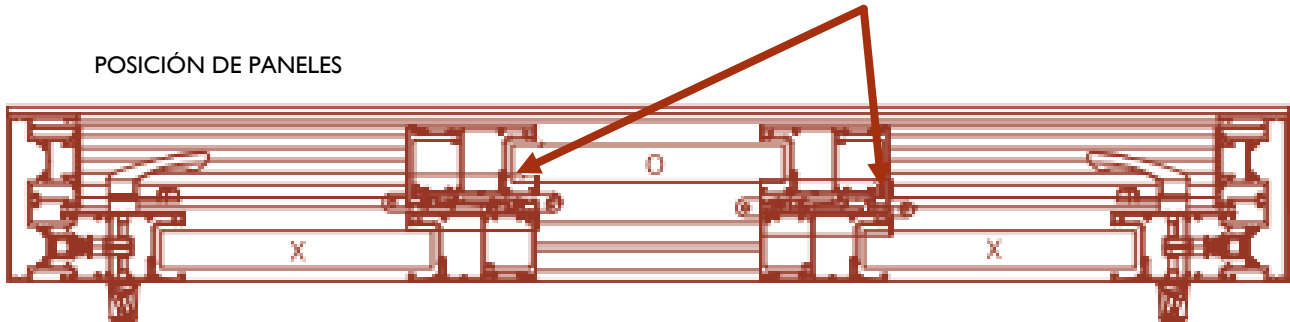

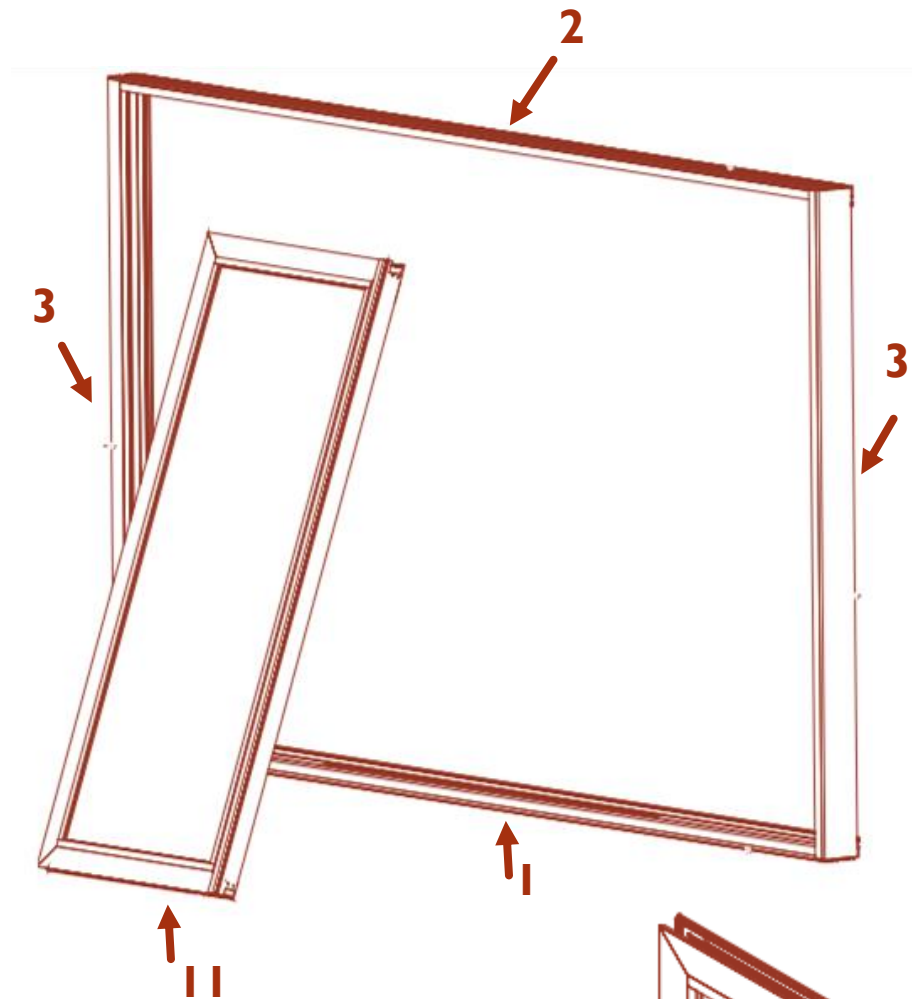

NOTA: TODOS LOS PANELES SON INSTALADOS DE LA MISMA MANERA

PARA LA POSICIÓN DE LOS PANELES DE LA CONFIGURACIÓN XOx, VER PÁGINA **TIPO DE PANELES**

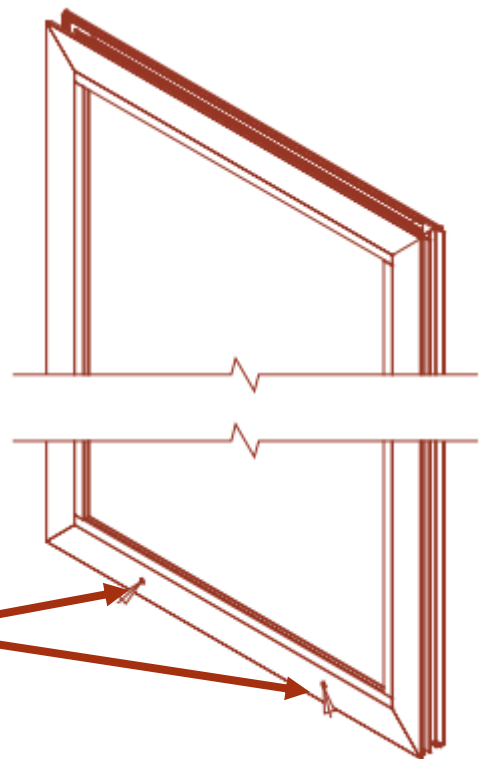

HUECOS DE AJUSTE EN LA PARTE INFERIOR

XOX COVERS INSTRUCCIONES

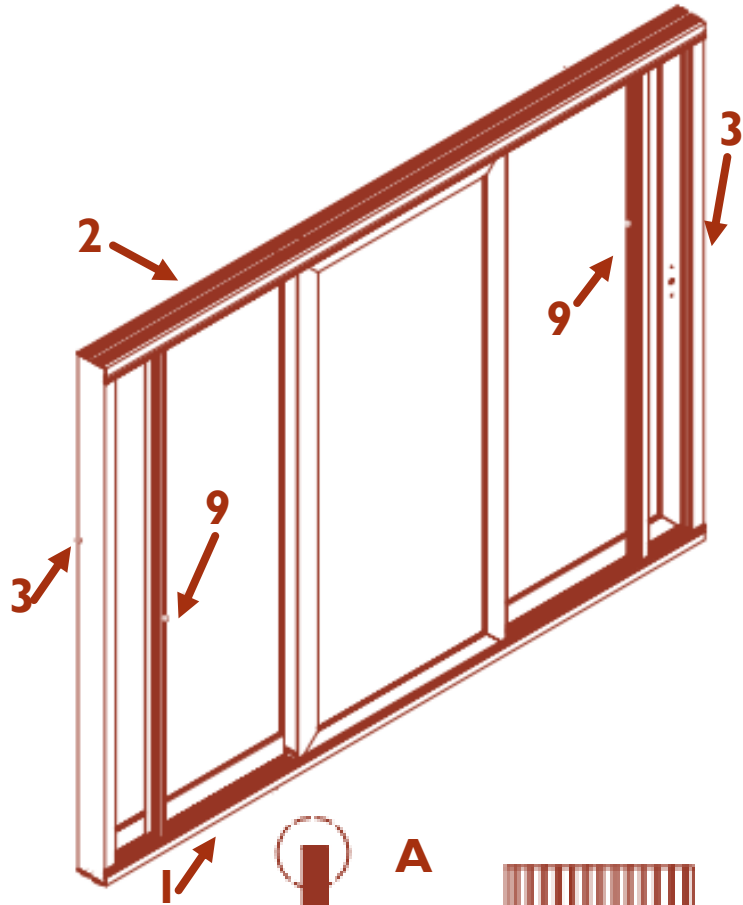

# Parte	Descripción
1	Sill (1U)
2	Head (1U)
3	Jamb (2U)
4	Hex Head #12 x 1 1/2" SMS, AISI 410 (16U)
5	Track Short (1U)
6	Track Long (1U)
7	Flat Cover Long (1U)
8	Flat Cover Short (1U)
9	Vertical Cover (2U)
10	Horizontal Cover (2U)
11	Air Seal Bridge (4U)
12	Panels (3U)
13	Bumper (2U)
14	PH-FH #10-16 x 3/4" SMS, AISI 316 (24U)
15	Roller Adjust Hole Plug (6U)
16	Bottom Panel Guide (4U)
17	Top Panel Guide (4U)
18	Striker (1U)
19	Lock Handle set (1U)
20	PH-PH #10-16 x 1" Self Drilling, AISI 410 (14U)
21	Fix Panel Attachment (2U)
22	PH-PH #10-16 x 1/2" SMS, AISI 316 (8U)

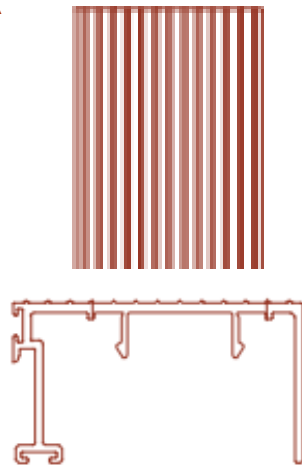
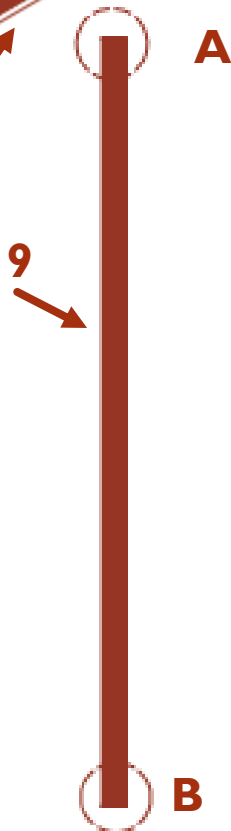

DETALLE A
ESCALA 1:3

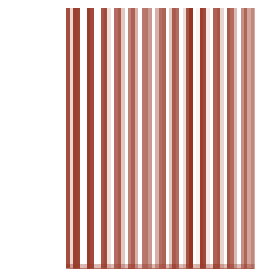

DETALLE B
ESCALA 1:3



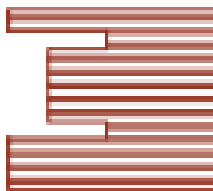
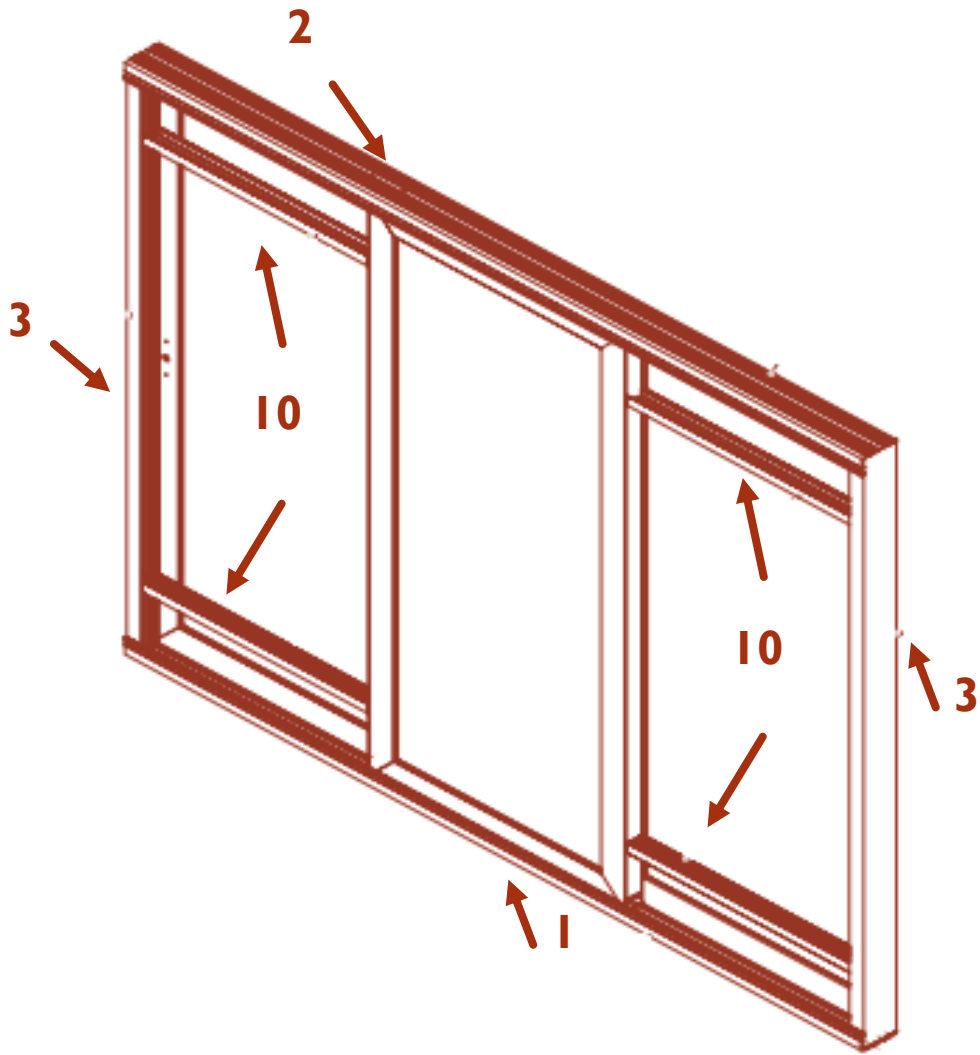

DETALLE D
ESCALA 1:3

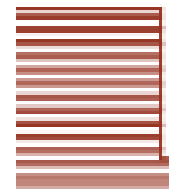

DETALLE C
ESCALA 1:3

XOX APLICACIÓN DE SILICONE INSTRUCCIONES

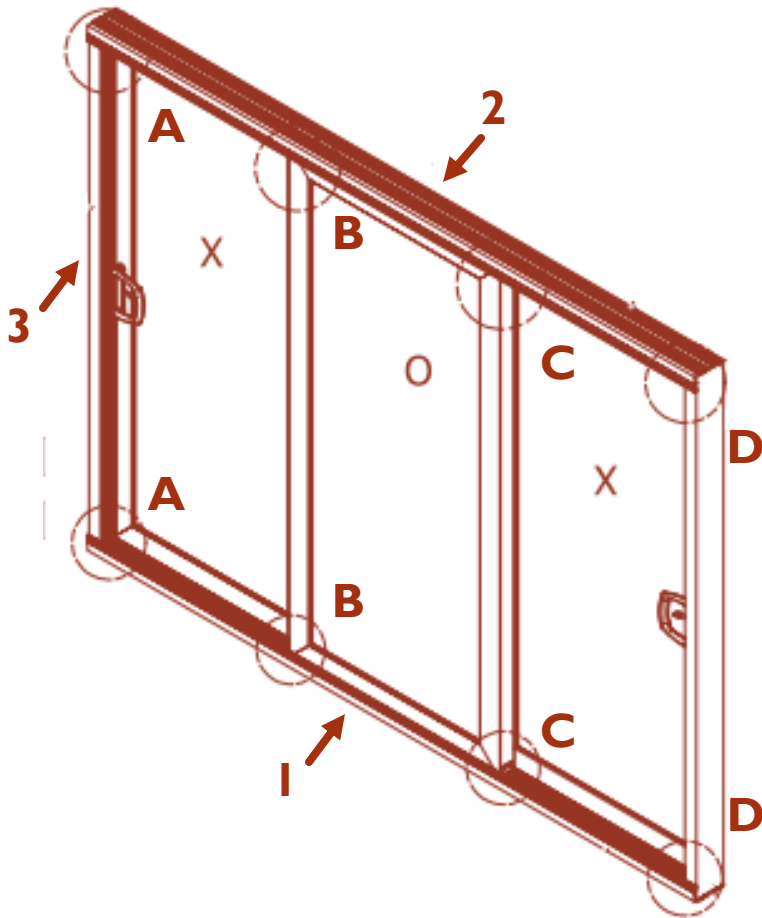

# Parte	Descripción
1	Sill (1U)
2	Head (1U)
3	Jambs (2U)
4	Hex Head #12 x 1 1/2" SMS. AISI 410 (16U)
5	Track Short (1U)
6	Track Long (1U)
7	Flat Cover Long (1U)
8	Flat Cover Short (1U)
9	Vertical Cover (2U)
10	Horizontal Cover (2U)
11	Air Seal Bridge (4U)
12	Panels (3U)
13	Bumper (2U)
14	PH-FH #10-16 x 3/4" SMS, AISI 316 (24U)
15	Roller Adjust Hole Plug (6U)
16	Bottom Panel Guide (4U)
17	Top Panel Guide (4U)
18	Striker (1U)
19	Lock Handle set (1U)
20	PH-PH #10-16 x 1" Self Drilling. AISI 410 (14U)
21	Fix Panel Attachment (2U)
22	PH-PH #10-16 x 1/2" SMS. AISI 316 (8U)

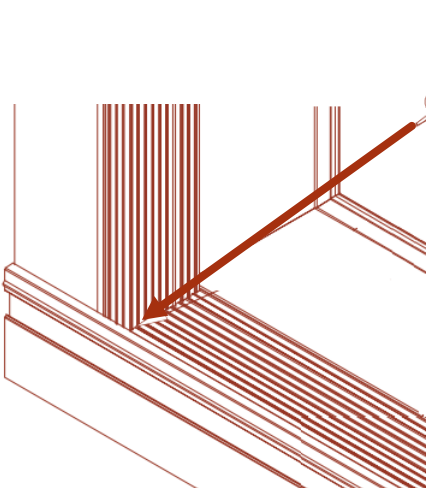

DETALLE A
ESCALA 1:6

AAPLIQUE SILICONA PARA UNIR LA
GASKET VERTICAL Y HORIZONTAL Y EL
COVER HORIZONTAL Y VERTICAL

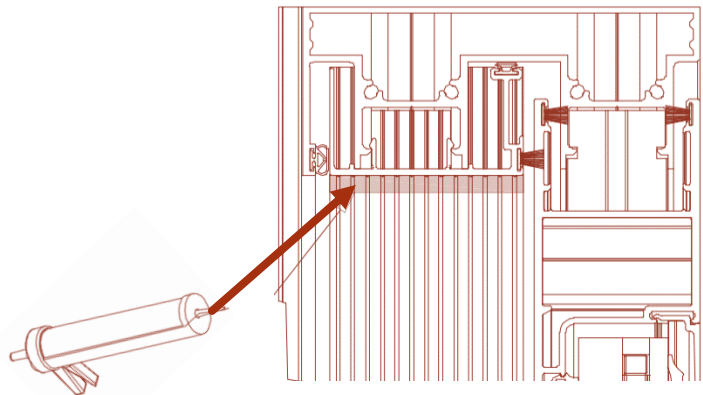

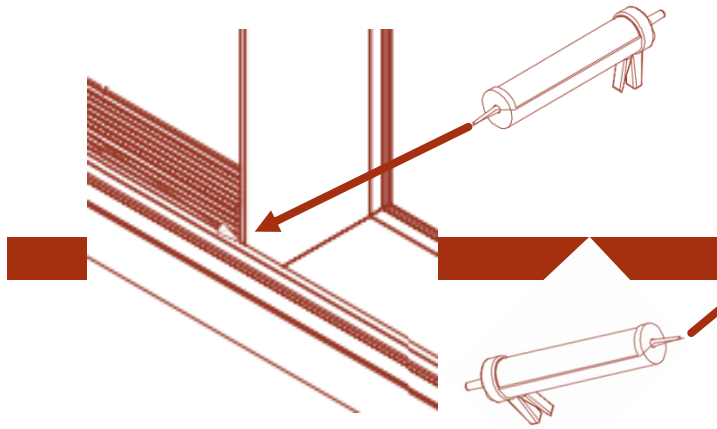

DETALLE B
ESCALA 1:6

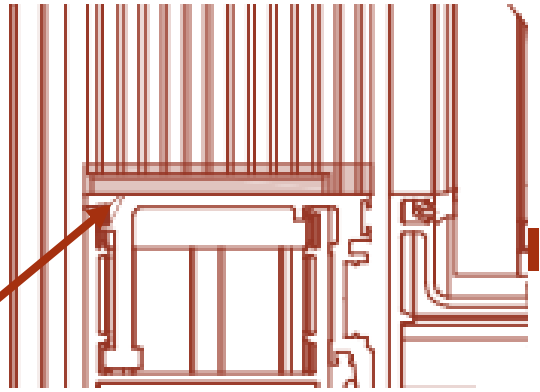

APLIQUE SILICONA PARA UNIR EL
WEATHERSTRIP EN EL LADO DE LA
PUERTA Y EL GASKET EN EL SILL

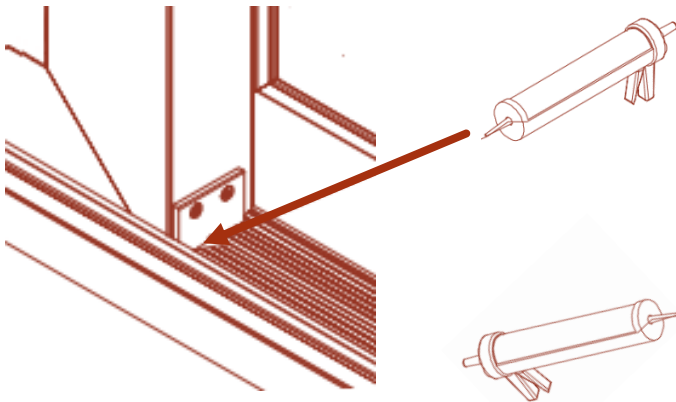

DETALLE C
ESCALA 1:6

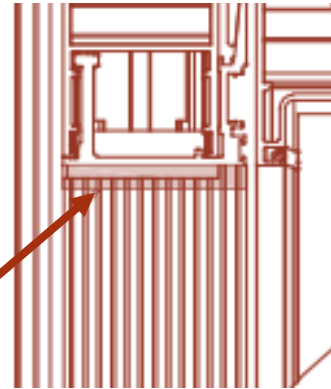

APLIQUE SILICONA PARA UNIR EL
WEATHERSTRIP EN EL LADO DE LA
PUERTA Y EL GASKET EN EL SILL

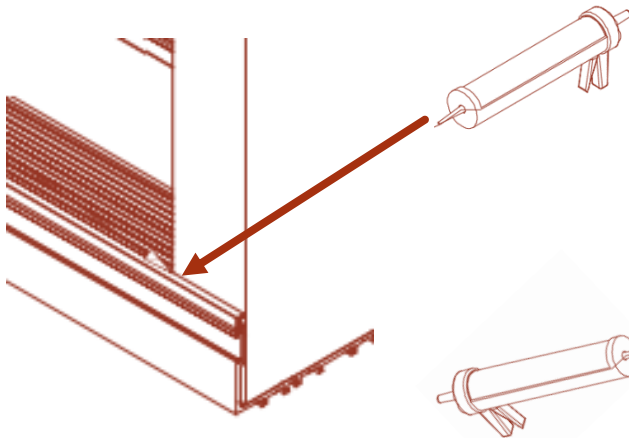

DETALLE D
ESCALA 1:6

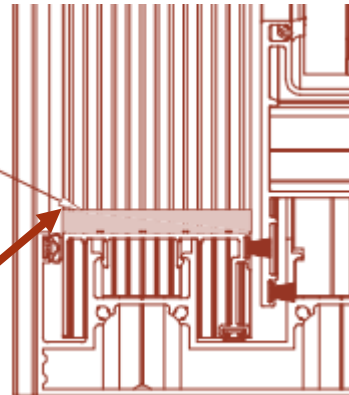

APLIQUE SILICONA PARA UNIR LA GASKET
VERTICAL Y HORIZONTAL Y EL COVER
HORIZONTAL Y VERTICAL

XOX INSTALACIÓN DE MANILLA INSTRUCCIONES

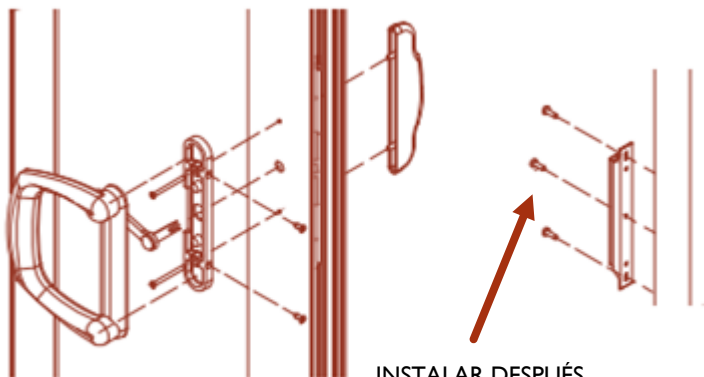

INSTALAR DESPUÉS
DE AJUSTAR CON
EL STRIKER

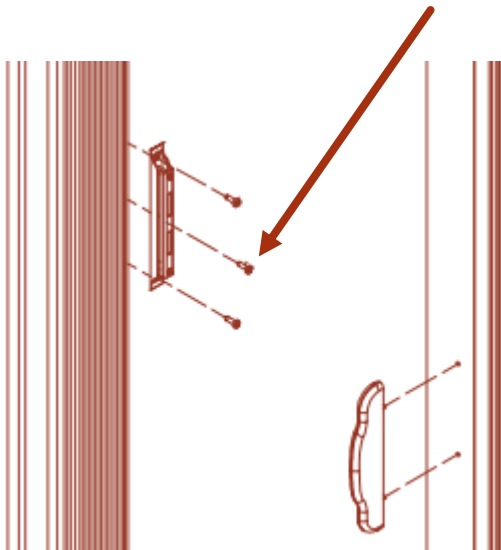

INSTALACIÓN DEL ROLLER AJUSTAR
EL PLUG Y LAS GUÍAS DE LOS
PANELES

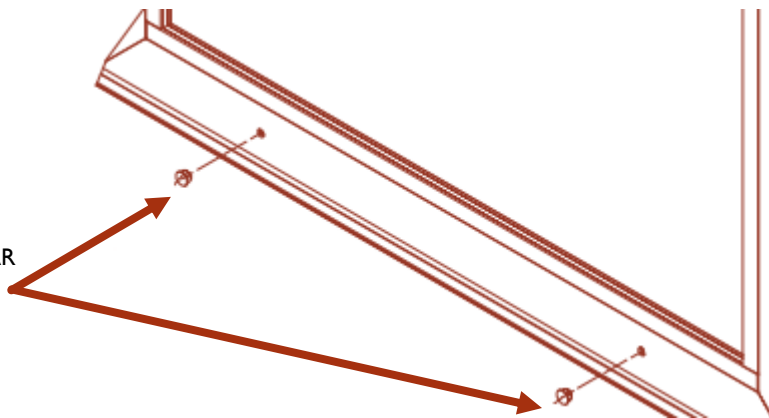





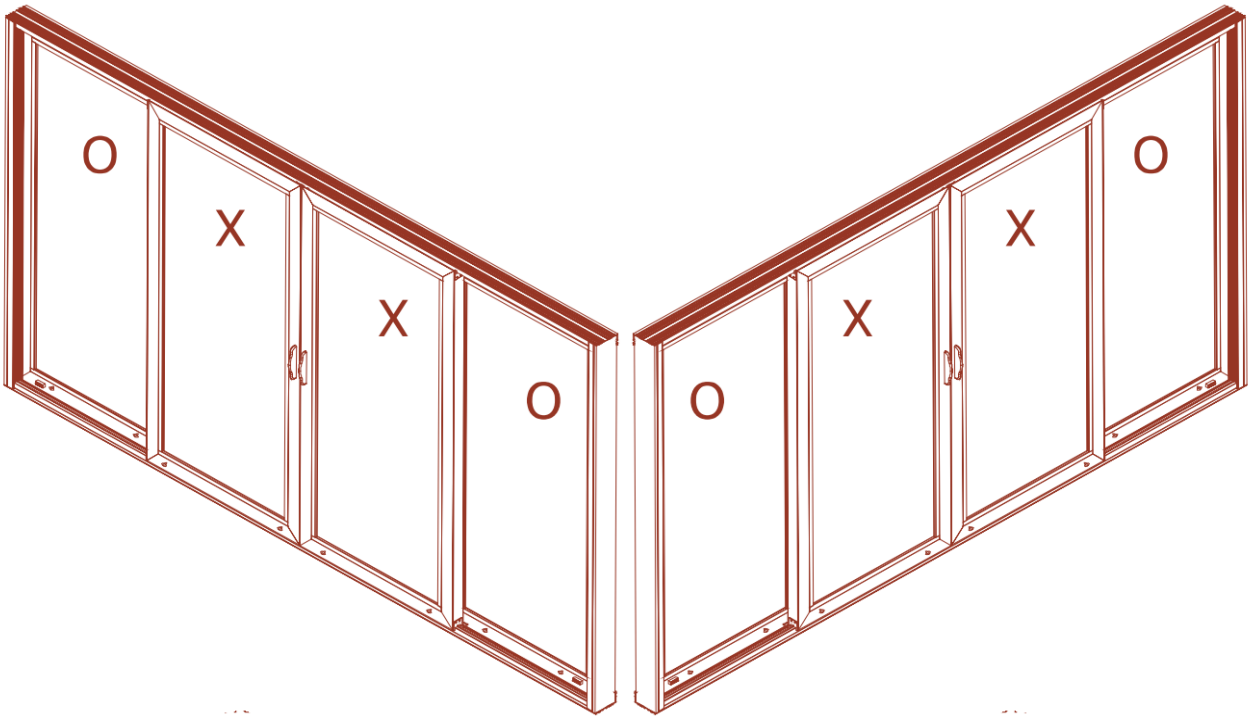

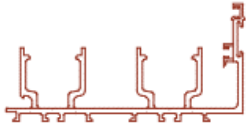
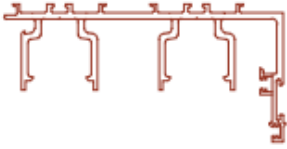

# Parte	Descripción
1	Sill (1U)
2	Head (1U)
3	Jambs (2U)
4	Hex Head #12 x 1 1/2" SMS. AISI 410 (16U)
5	Track Short (1U)
6	Track Long (1U)
7	Flat Cover Long (1U)
8	Flat Cover Short (1U)
9	Vertical Cover (2U)
10	Horizontal Cover (2U)
11	Air Seal Bridge (4U)
12	Panels (3U)
13	Bumper (2U)
14	PH-FH #10-16 x 3/4" SMS, AISI 316 (24U)
15	Roller Adjust Hole Plug (6U)
16	Bottom Panel Guide (4U)
17	Top Panel Guide (4U)
18	Striker (1U)
19	Lock Handle set (1U)
20	PH-PH #10-16 x 1" Self Drilling. AISI 410 (14U)
21	Fix Panel Attachment (2U)
22	PH-PH #10-16 x 1/2" SMS. AISI 316 (8U)







OXXO PARTES

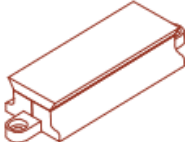

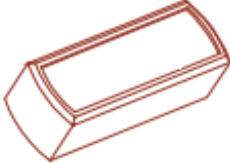
PARA LA CONFIGURACIÓN OXXO VER PAGINAS 89-92 PARA LA SELECCIÓN DE TIPO DE PANEL

# Parte	Descripción	Imagen
1	Sill (1U)	
2	Head (1U)	
3	Jams (2U)	

4	Hex Head #12 x 1 1/2" SMS. AISI 410 (16U)	
5	Track Short (2U)	
6	Track Long (1U)	
7	Flat Cover Long (1U)	
8	Flat Cover Short (2U)	
9	Vertical Cover (2U)	
10	Horizontal Cover (2U)	
11	Air Seal Bridge (4U)	

12	Panels (4U)	
13	Bumper (2U)	
14	PH-FH #10-16 x 3/4" SMS, AISI 316 (32U)	
15	Roller Adjust Hole Plug (6U)	
16	Bottom Panel Guide (4U)	
17	Top Panel Guide (4U)	
18	Striker (1U)	

19	Door Handle Set (1U)	
20	Lock Handle set (1U)	
21	PH-PH #10-16 x 1" Self Drilling. AISI 410 (12U)	
22	PH-PH #10-16 x 1/2" SMS. AISI 316 (8U)	

OXXO TRACK INSTRUCCIONES

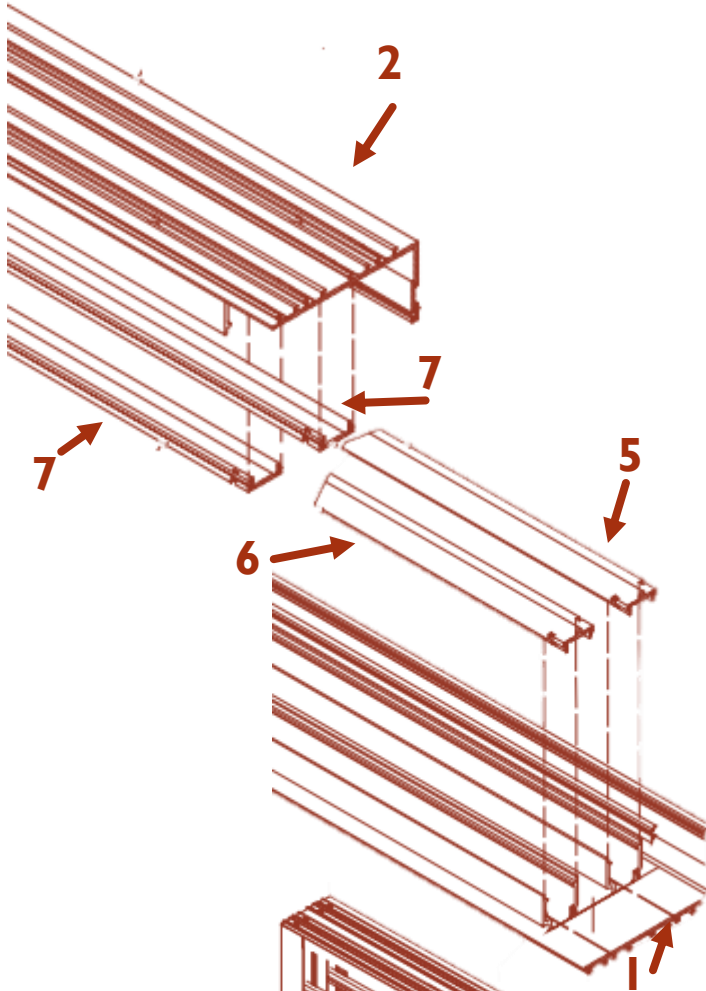

# Parte	Descripción
1	Sill (1U)
2	Head (1U)
3	Jambs (2U)
4	Hex Head #12 x 1 1/2" SMS. AISI 410 (16U)
5	Track Short (2U)
6	Track Long (1U)
7	Flat Cover Long (1U)
8	Flat Cover Short (2U)
9	Vertical Cover (2U)
10	Horizontal Cover (2U)
11	Air Seal Bridge (4U)
12	Panels (4U)
13	Bumper (2U)
14	PH-FH #10-16 x 3/4" SMS, AISI 316 (32U)
15	Roller Adjust Hole Plug (6U)
16	Bottom Panel Guide (4U)
17	Top Panel Guide (4U)
18	Striker (1U)
19	Door Handle Set (1U)
20	Lock Handle set (1U)
21	PH-PH #10-16 x 1" Self Drilling, AISI 410 (12U)
22	PH-PH #10-16 x 1/2" SMS, AISI 316 (8U)

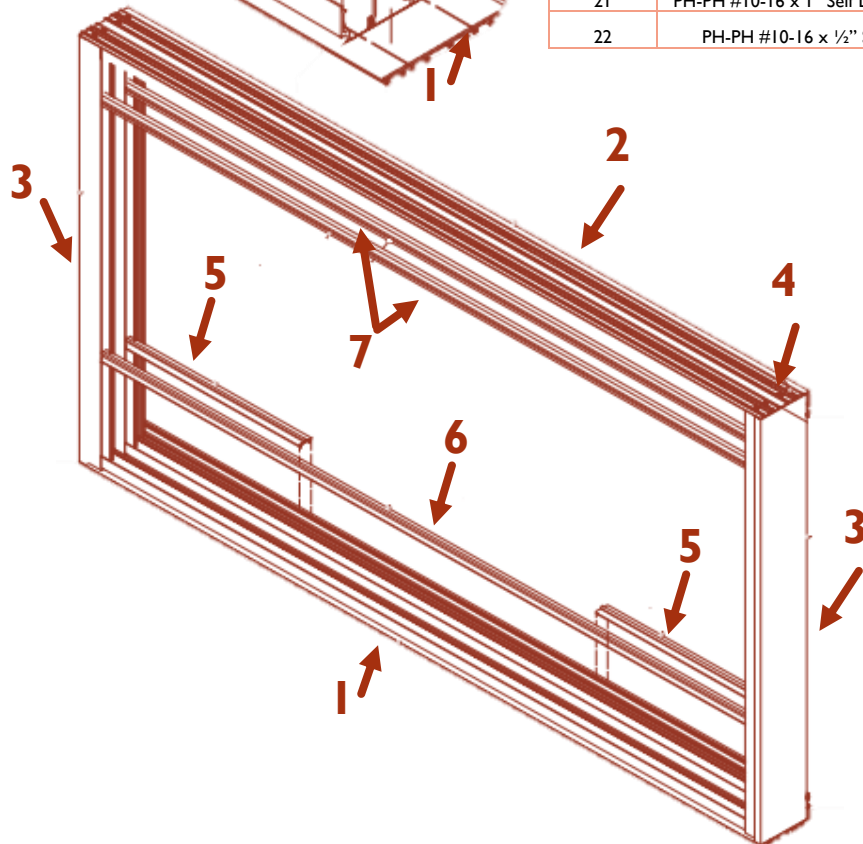

OXXO PANELES INSTRUCCIONES

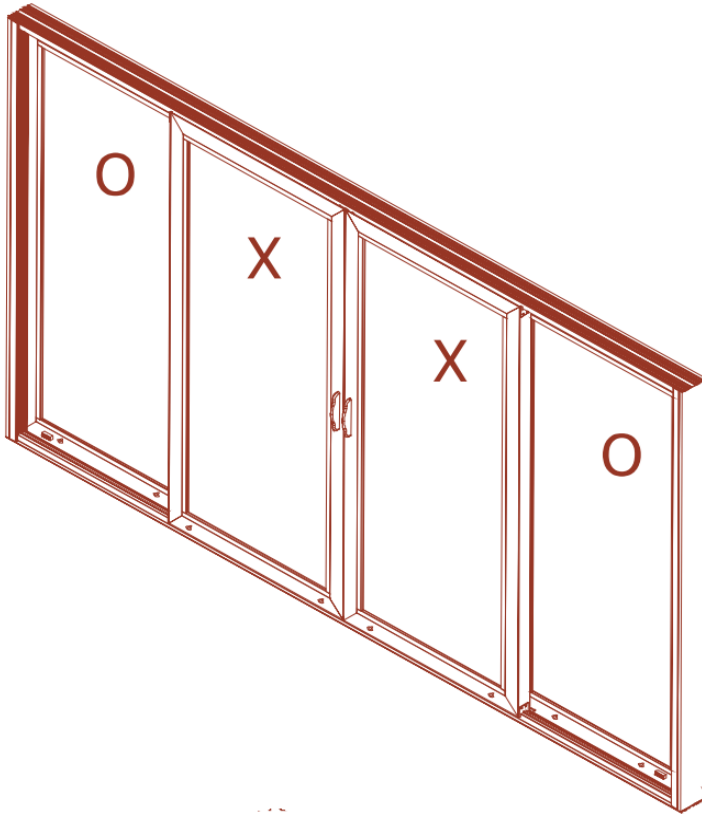

# Parte	Descripción
1	Sill (1U)
2	Head (1U)
3	Jambs (2U)
4	Hex Head #12 x 1 1/2" SMS. AISI 410 (16U)
5	Track Short (2U)
6	Track Long (1U)
7	Flat Cover Long (1U)
8	Flat Cover Short (2U)
9	Vertical Cover (2U)
10	Horizontal Cover (2U)
11	Air Seal Bridge (4U)
12	Panels (4U)
13	Bumper (2U)
14	PH-FH #10-16 x 3/4" SMS, AISI 316 (32U)
15	Roller Adjust Hole Plug (6U)
16	Bottom Panel Guide (4U)
17	Top Panel Guide (4U)
18	Striker (1U)
19	Door Handle Set (1U)
20	Lock Handle set (1U)
21	PH-PH #10-16 x 1" Self Drilling. AISI 410 (12U)
22	PH-PH #10-16 x 1/2" SMS. AISI 316 (8U)

POSICIÓN DE EL AIRE SEAL BRIDGE EN EL SILL & HEAD. NO PUEDE ESTAR EN LA POSICIONA FINAL DURANTE LA INSTALACIÓN DE LOS PANELES

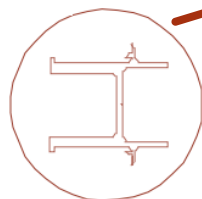
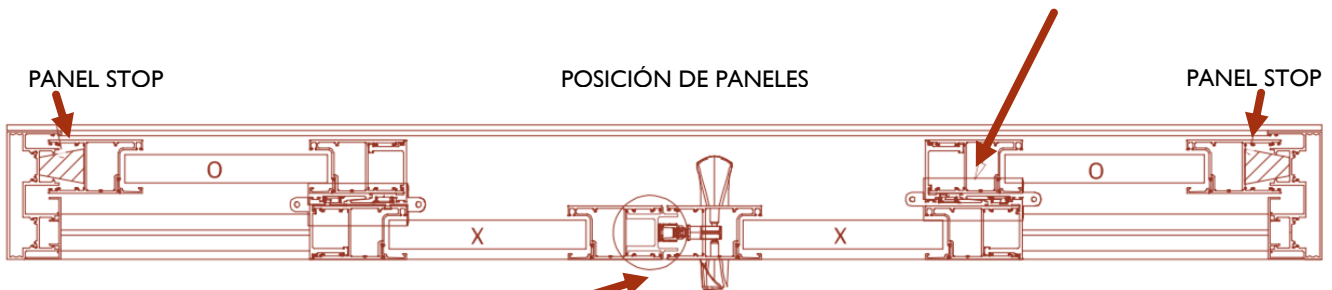

REMOVER QUITANDO LOS TORNILLOS PARA INSTALACIÓN DE EL PANEL & REINSTALAR DESPUÉS QUE ESTE SE ENCUENTRE EN LA POSICIÓN FINAL Y LOS ACCESORIOS #21 ESTÁN EN SU LUGAR.

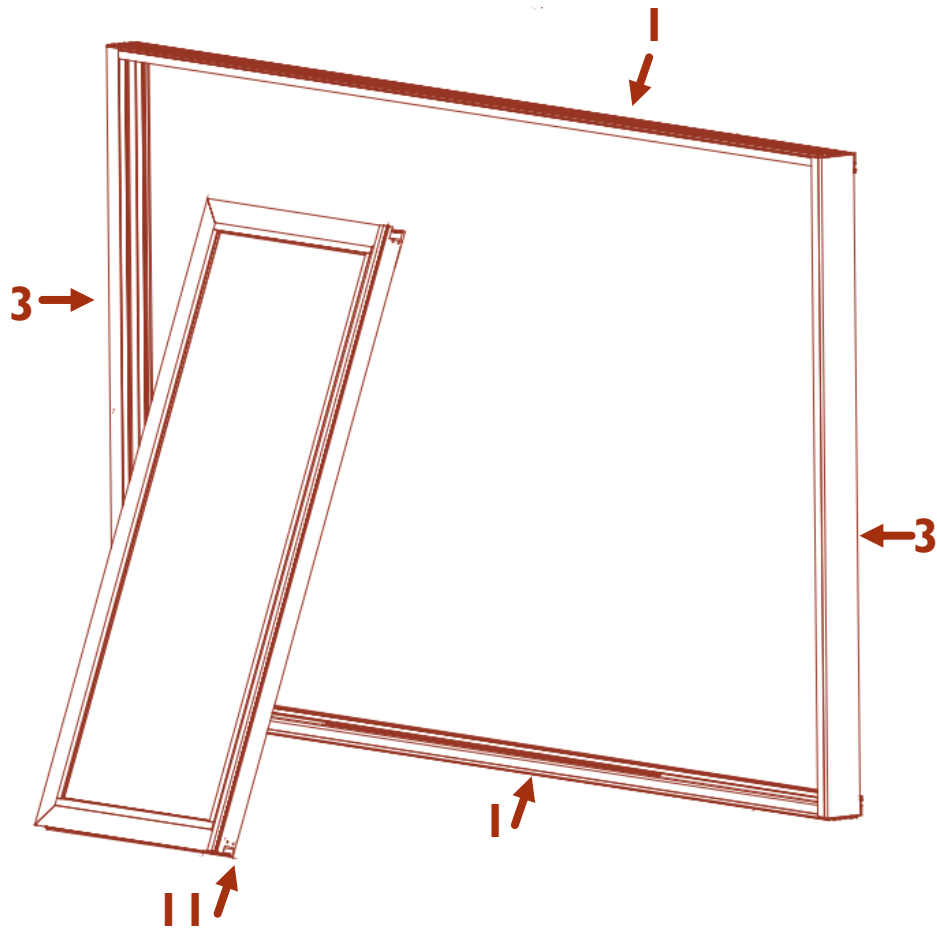

NOTA:

- TODOS LOS PANELES SON INSTALADOS DE LA MISMA MANERA
- PANELES DE TIPO A & D SON FIJOS Y DEBEN SER INSTALADOS EN EL TRACK DEL EXTERIOR
- PANELES DE TIPO B & G SON MÓVILES Y DEBEN SER INSTALADOS EN EL TRACK DEL INTERIOR
- PARA LA POSICIÓN DE LOS PANELES DE LA CONFIGURACIÓN OXXO, VER PAGINA **TIPO DE PANELES**

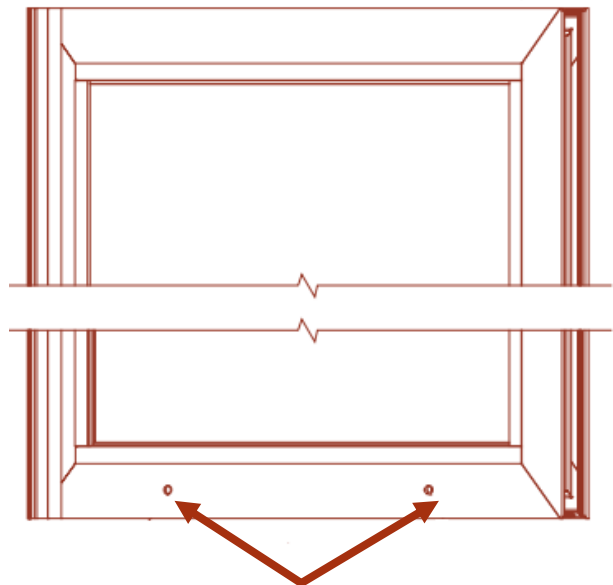

HUECOS DE AJUSTE EN LA PARTE INFERIOR

OXXO COVERS INSTRUCCIONES

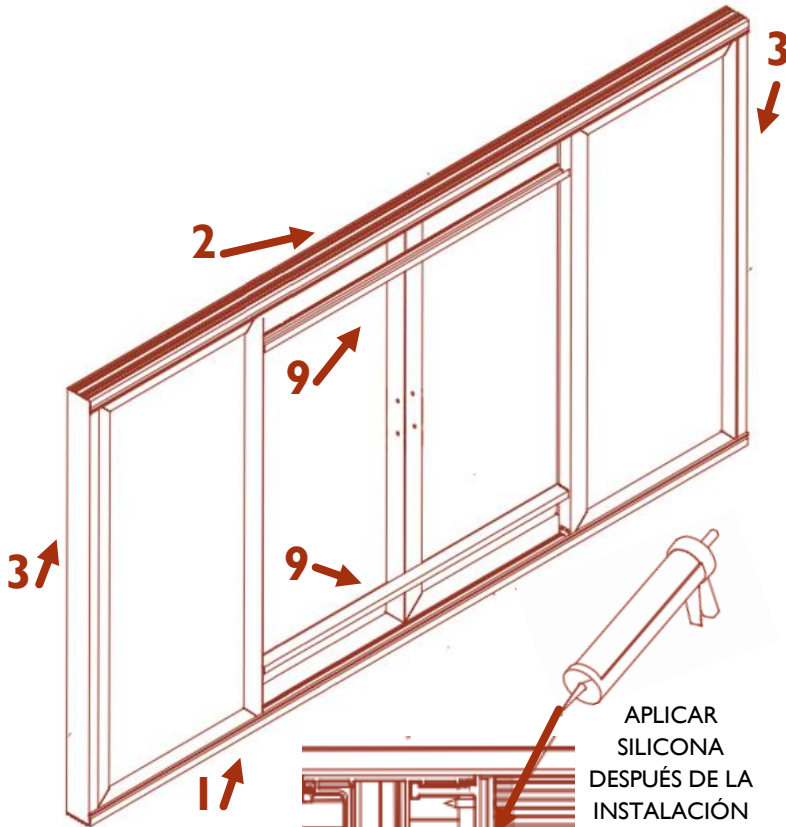

# Parte	Descripción
1	Sill (1U)
2	Head (1U)
3	Jambs (2U)
4	Hex Head #12 x 1 1/2" SMS. AISI 410 (16U)
5	Track Short (2U)
6	Track Long (1U)
7	Flat Cover Long (1U)
8	Flat Cover Short (2U)
9	Vertical Cover (2U)
10	Horizontal Cover (2U)
11	Air Seal Bridge (4U)
12	Panels (4U)
13	Bumper (2U)
14	PH-FH #10-16 x 3/4" SMS, AISI 316 (32U)
15	Roller Adjust Hole Plug (6U)
16	Bottom Panel Guide (4U)
17	Top Panel Guide (4U)
18	Striker (1U)
19	Door Handle Set (1U)
20	Lock Handle set (1U)
21	PH-PH #10-16 x 1" Self Drilling, AISI 410 (12U)
22	PH-PH #10-16 x 1/2" SMS, AISI 316 (8U)

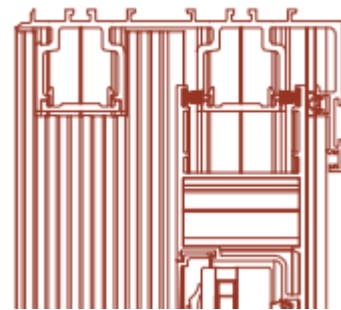
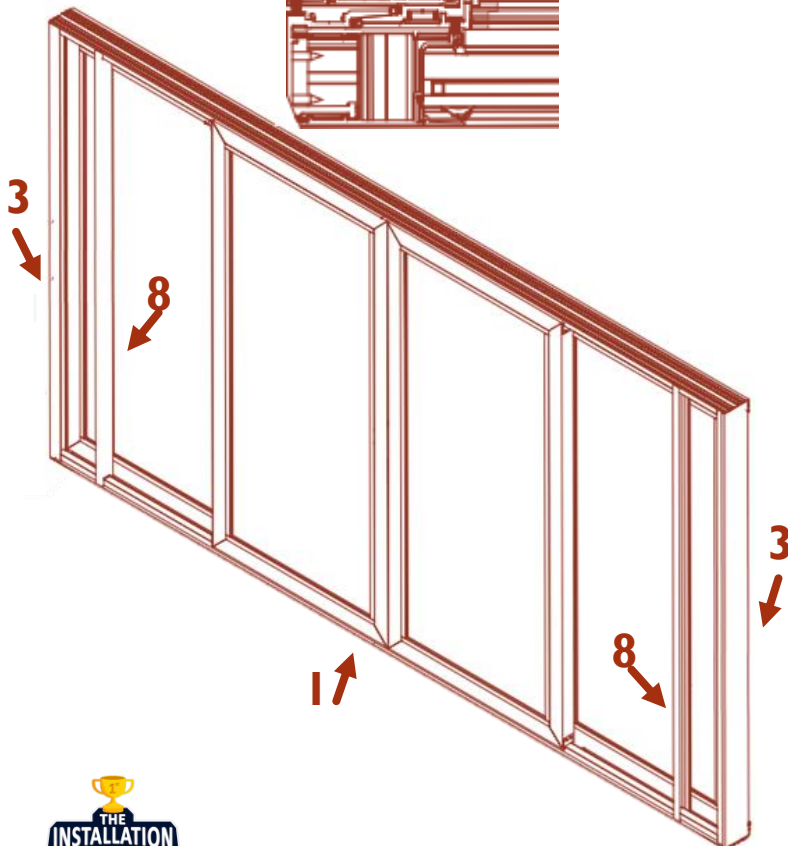

OXO APLICACIÓN DE SILICONE INSTRUCCIONES

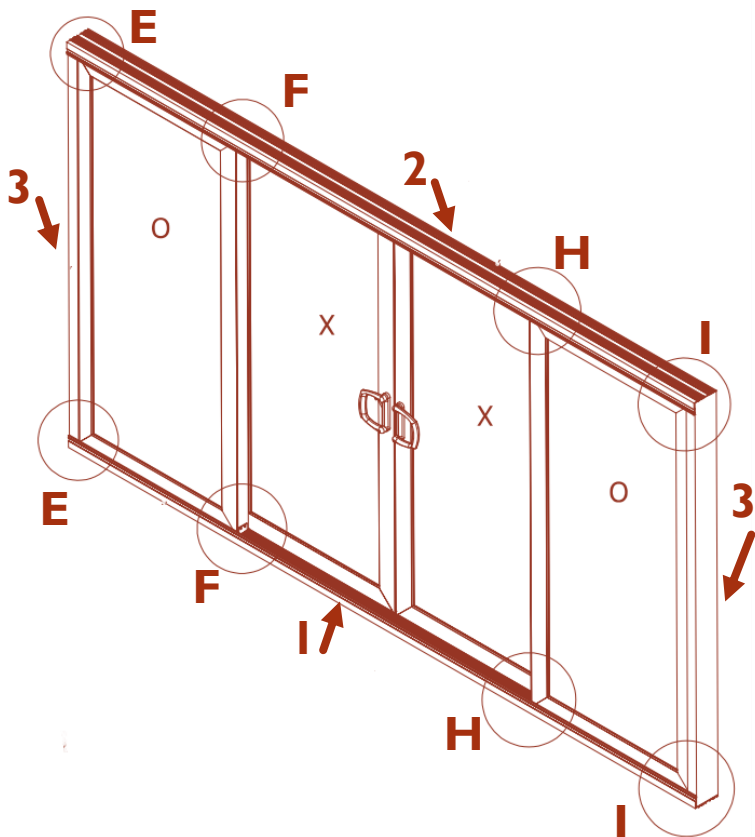

# Parte	Descripción
1	Sill (1U)
2	Head (1U)
3	Jambs (2U)
4	Hex Head #12 x 1 1/2" SMS. AISI 410 (16U)
5	Track Short (2U)
6	Track Long (1U)
7	Flat Cover Long (1U)
8	Flat Cover Short (2U)
9	Vertical Cover (2U)
10	Horizontal Cover (2U)
11	Air Seal Bridge (4U)
12	Panels (4U)
13	Bumper (2U)
14	PH-FH #10-16 x 3/4" SMS, AISI 316 (32U)
15	Roller Adjust Hole Plug (6U)
16	Bottom Panel Guide (4U)
17	Top Panel Guide (4U)
18	Striker (1U)
19	Door Handle Set (1U)
20	Lock Handle set (1U)
21	PH-PH #10-16 x 1" Self Drilling. AISI 410 (12U)
22	PH-PH #10-16 x 1/2" SMS. AISI 316 (8U)

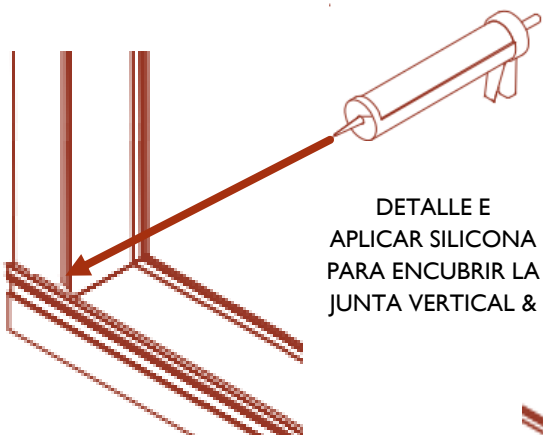

DETALLE E
 APLICAR SILICONA
 PARA ENCUBRIR LA
 JUNTA VERTICAL &

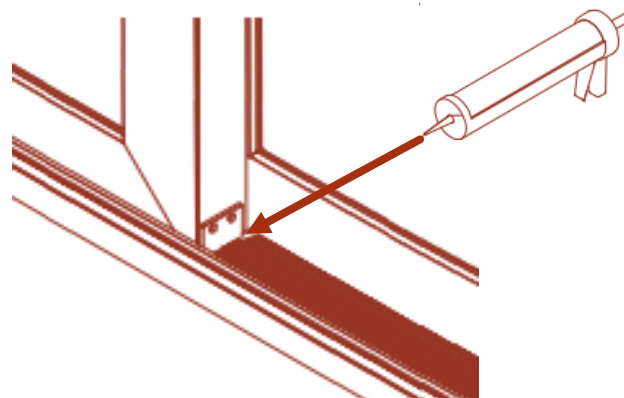

DETALLE F
 APLICAR SILICONA PARA ENCUBRIR
 EL WEATHERSTRIP CON EL LADO DE
 LA PUERTA Y GASKET EN EL SILL

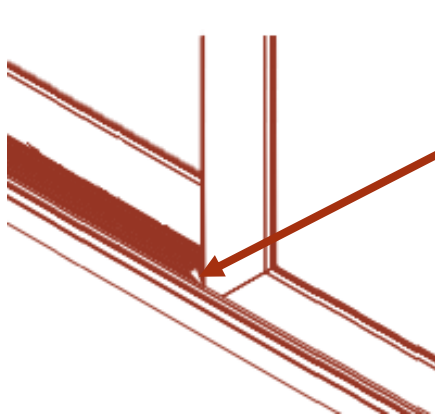

DETALLE H
APLICAR SILICONA PARA ENCUBRIR
EL WEATHERSTRIP CON EL LADO DE
LA PUERTA & GASKET EN EL SILL

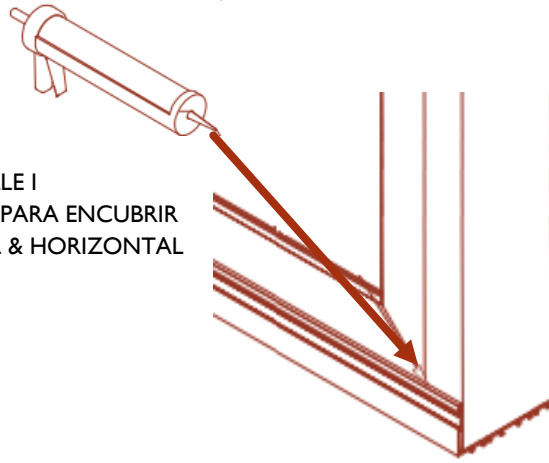

DETALLE I
APLICAR SILICONA PARA ENCUBRIR
LA JUNTA VERTICAL & HORIZONTAL

OXXO INSTALACIÓN DE MANILLA INSTRUCCIONES

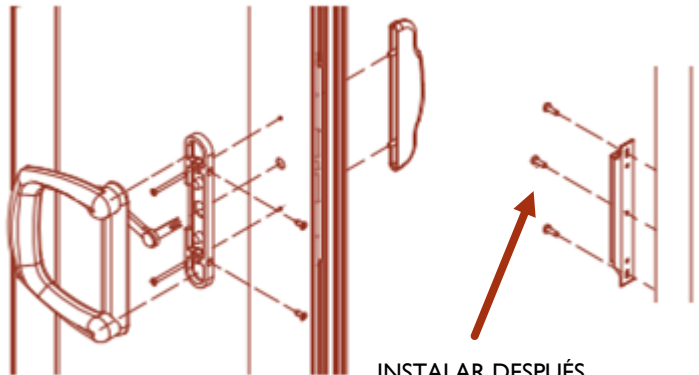

INSTALACIÓN DEL CERRAJE DE LA PUERTA

INSTALAR DESPUÉS DE AJUSTAR CON EL STRIKER

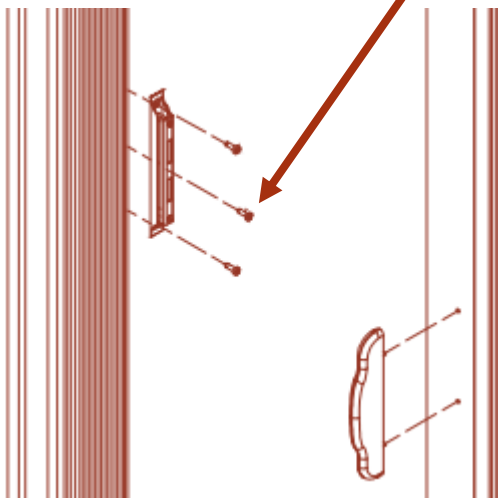

INSTALACIÓN DEL HANDLE DE LA PUERTA

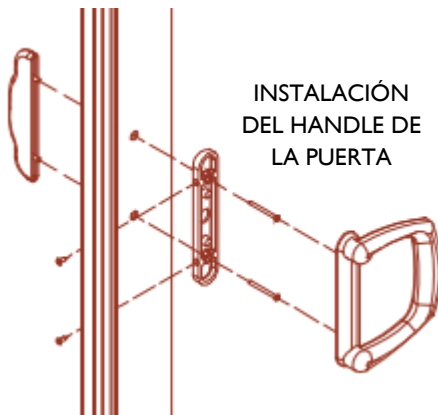

INSTALACIÓN DEL ROLLER AJUSTAR EL PLUG Y LAS GUÍAS DE LOS PANELES

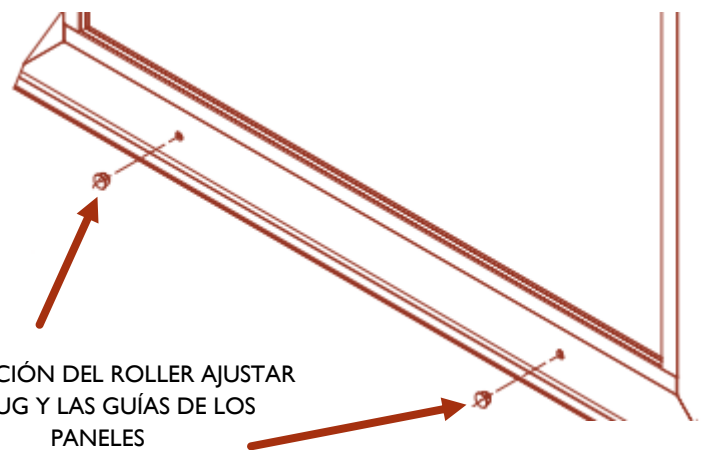

# Parte	Descripción
1	Sill (1U)
2	Head (1U)
3	Jambs (2U)
4	Hex Head #12 x 1 1/2" SMS. AISI 410 (16U)
5	Track Short (2U)
6	Track Long (1U)
7	Flat Cover Long (1U)
8	Flat Cover Short (2U)
9	Vertical Cover (2U)
10	Horizontal Cover (2U)
11	Air Seal Bridge (4U)
12	Panels (4U)
13	Bumper (2U)
14	PH-FH #10-16 x 3/4" SMS, AISI 316 (32U)
15	Roller Adjust Hole Plug (6U)
16	Bottom Panel Guide (4U)
17	Top Panel Guide (4U)
18	Striker (1U)
19	Door Handle Set (1U)
20	Lock Handle set (1U)
21	PH-PH #10-16 x 1" Self Drilling, AISI 410 (12U)
22	PH-PH #10-16 x 1/2" SMS, AISI 316 (8U)

INSTALACIÓN DE PUERTA CORREDIZA

INSTALACIÓN CON JAMB

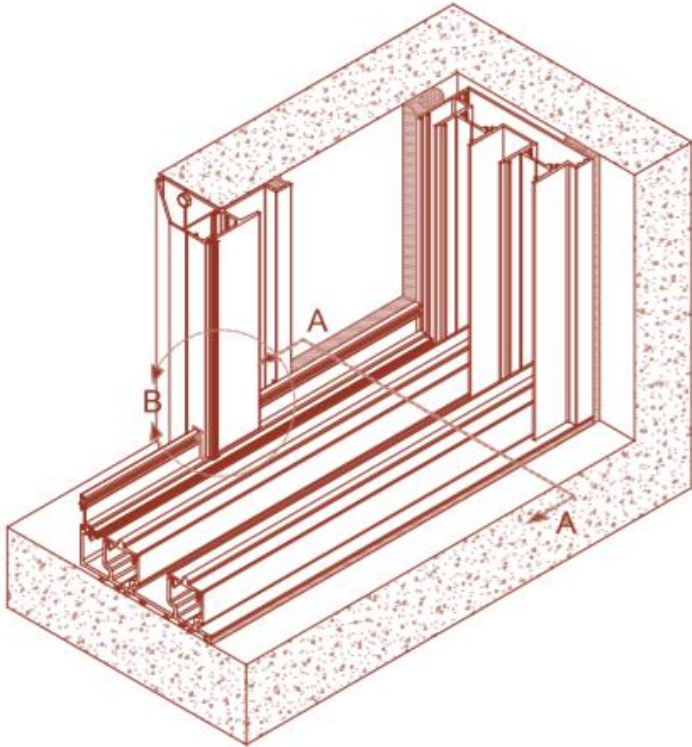

INSTALACIÓN SIN JAMB

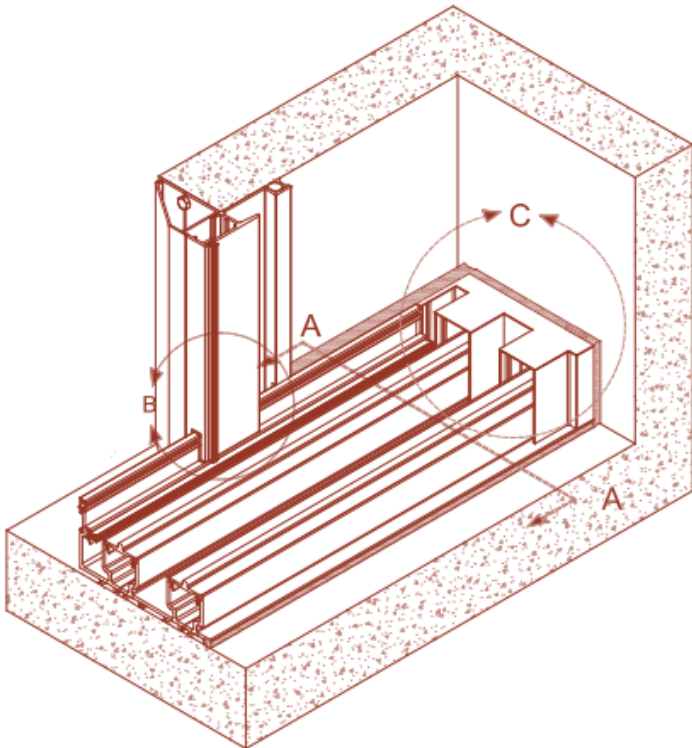

G10-11 (AIR SEAL BRIDGE)

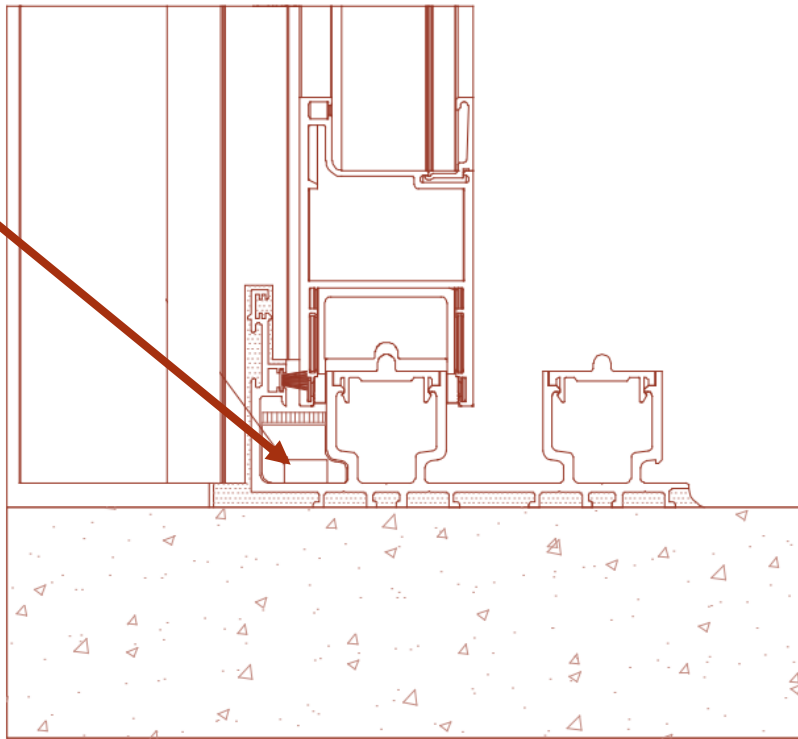

DETALLE A

9/16" ULTRACON VER F.A

SELLAR ENTRE EL NOTCH DE EL HOOK-STRIP Y EL SILL

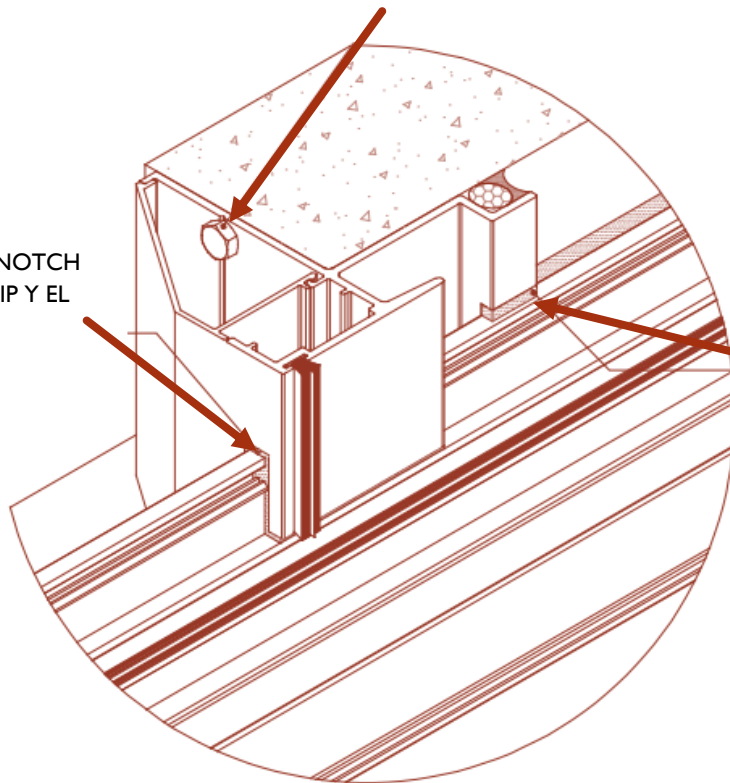

SELLAR ENTRE EL NOTCH DE EL HOOK-STRIP Y EL SILL

DETALLE B

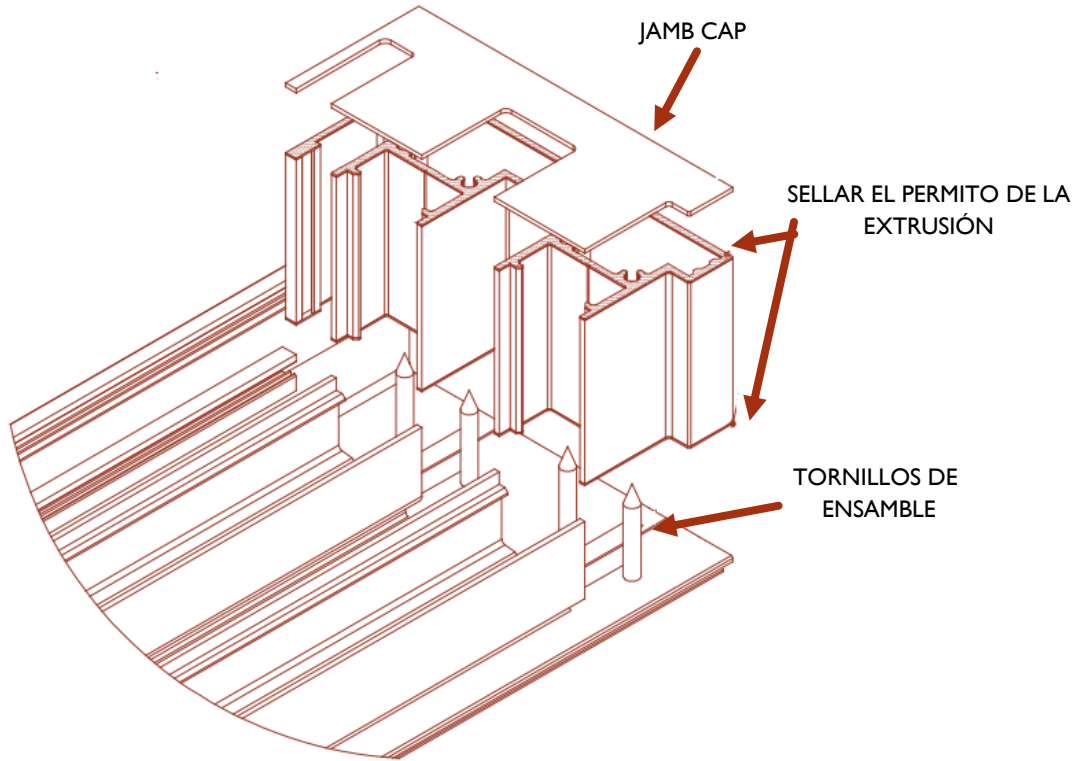

DETALLE C

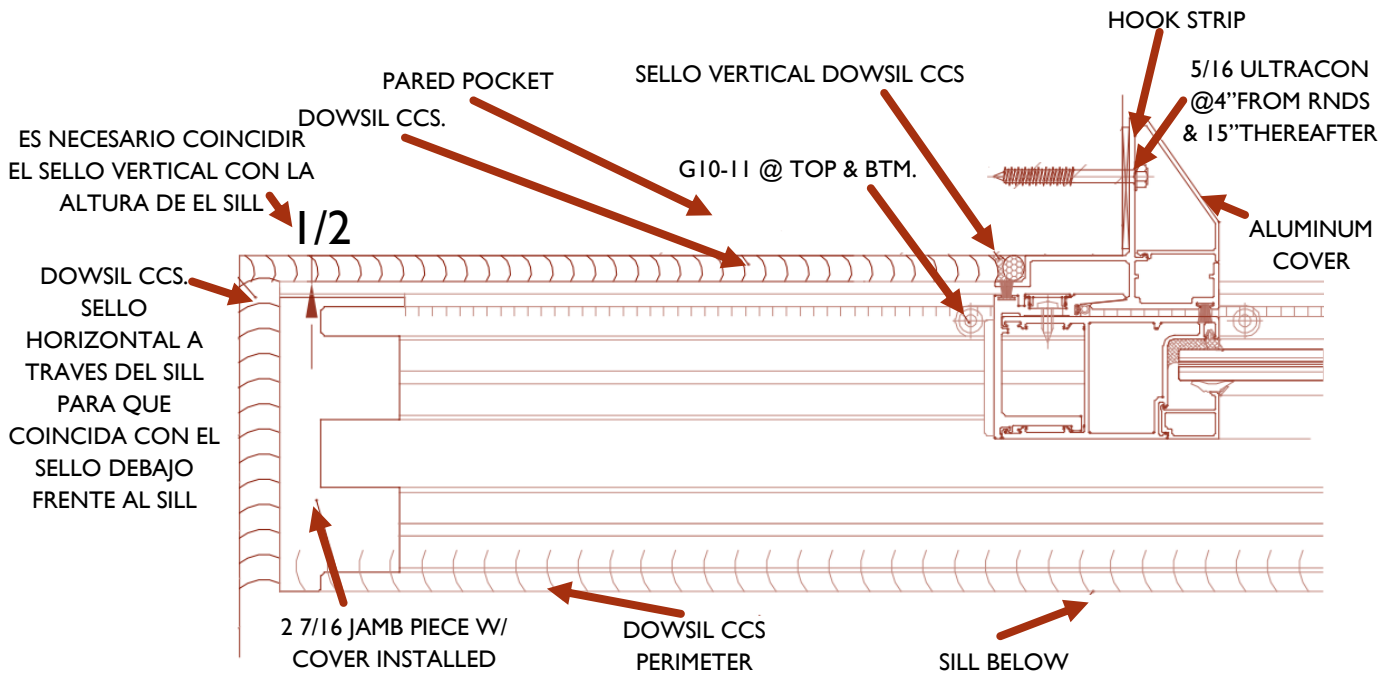

DETALLE DE INSTALACIÓN SIN JAMB





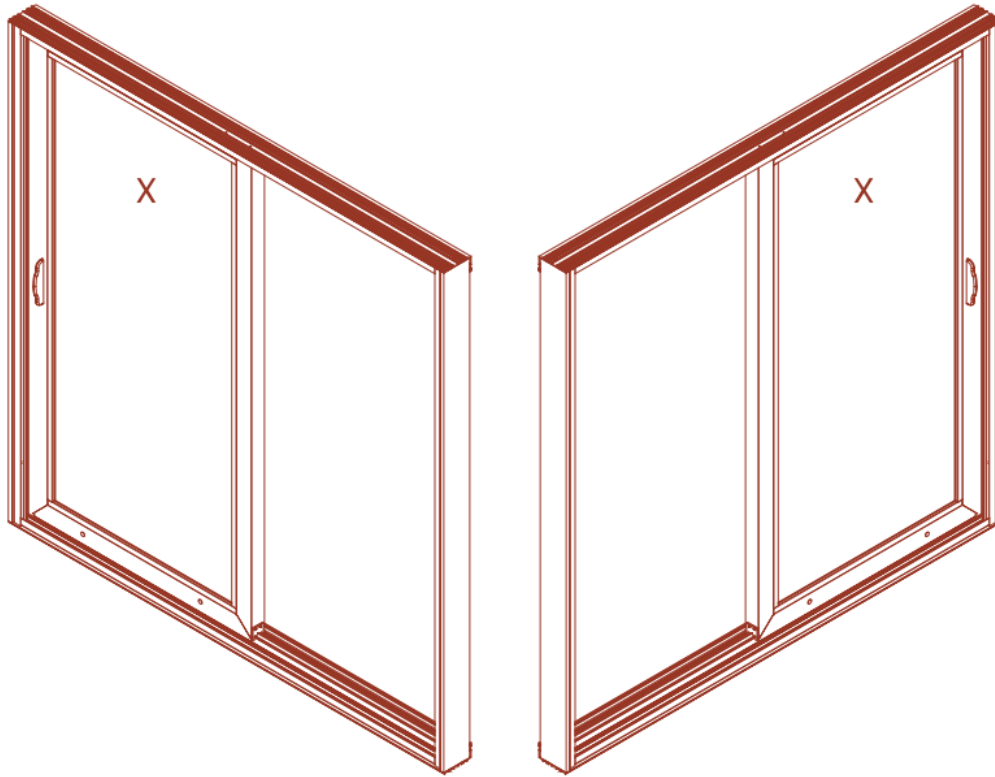



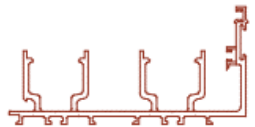
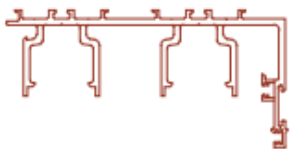
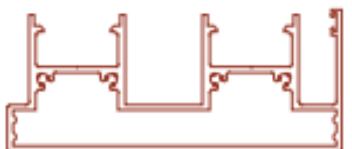

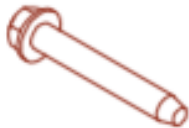
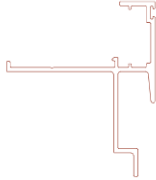
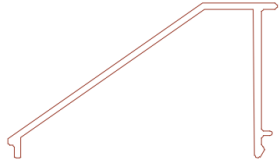

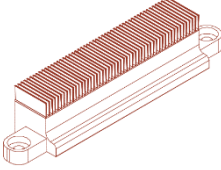

XP Y PX KD PAQUETE

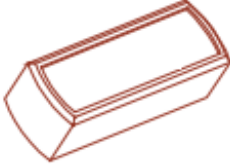

PARA LA CONFIGURACIÓN XP/PX VER PAGINAS 89-92 PARA LA SELECCIÓN DE TIPO DE PANEL

# Parte	Descripción	Imagen
1	Sill (1U)	
2	Head (1U)	
3	Jambs (2U)	

4	Hex Head #12 x 1 1/2" SMS. AISI 410 (16U)	
5	Hook Strip (IU)	
6	Hook Strip Cover (IU)	
7	Track Long (IU)	
8	Flat Cover Long (3U)	
9	PH-PH #10-16 x 1" Self Drilling. AISI 410 (8U)	
10	Vertical Cover (IU)	
11	Air Seal Bridge G10-11(IU)	

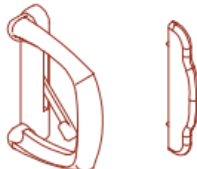

12	Panel (1U)	
13	Bumper (2U)	
14	PH-FH #10-16 x 3/4' SMS, AISI 316 (4U)	
15	Roller Adjust Hole Plug (2U)	
16	Bottom Panel Guide (1U)	
17	Top Panel Guide (1U)	
18	Striker (1U)	
19	Lock Handle set (1U)	



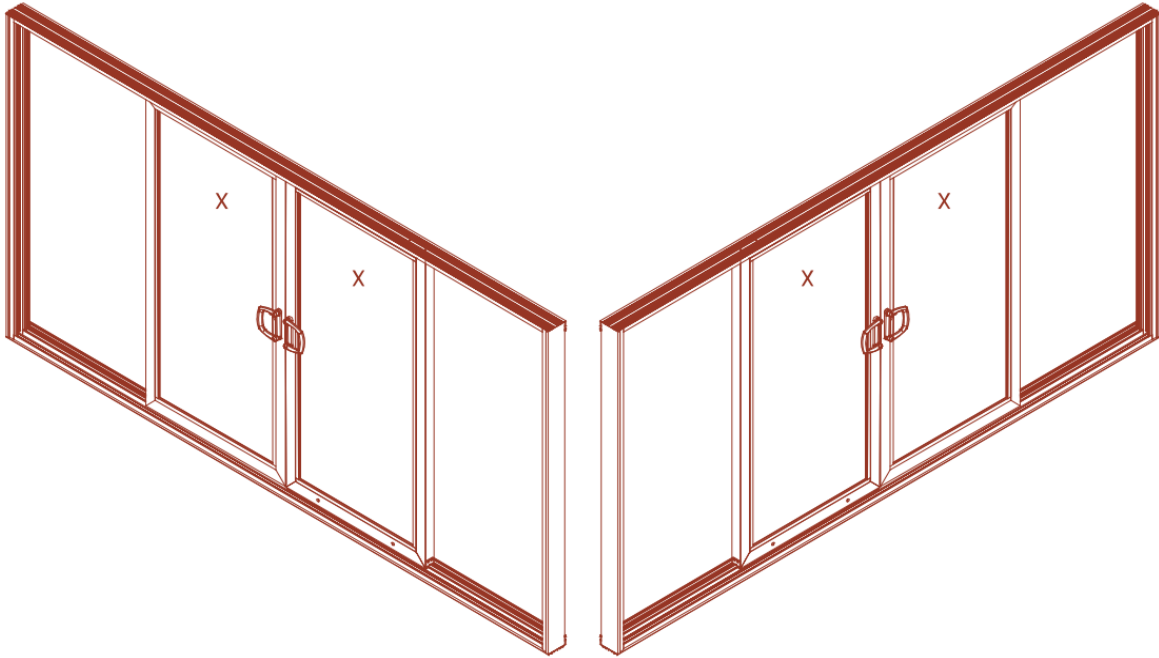

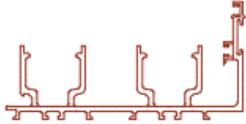
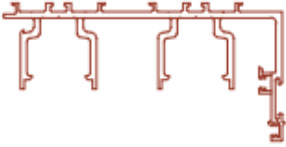

20	PH-PH #10-16 x 1/2" SMS. AISI 316 (4U)	
----	----------------------------------------	-------------------------------------------------------------------------------------



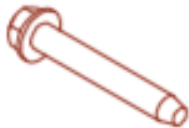
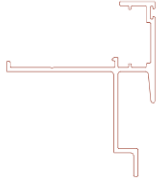
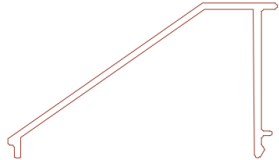



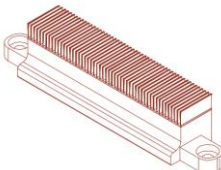

PXXP KD PACKAGE

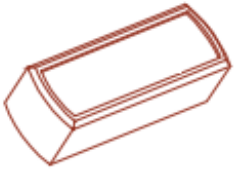

PARA LA CONFIGURACIÓN PXXP VER PAGINAS 89-92 PARA LA SELECCIÓN DE TIPO DE PANEL

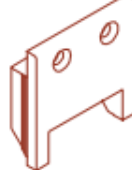
# Parte	Descripción	Imagen
1	Sill (1U)	
2	Head (1U)	
3	Jambs (2U)	

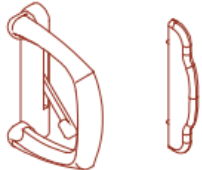
4	Hex Head #12 x 1 1/2" SMS. AISI 410 (16U)	
5	Hook Strip (2U)	
6	Hook Strip Cover (2U)	
7	Track Long (1U)	
8	Flat Cover Long (3U)	
9	PH-PH #10-16 x 1" Self Drilling. AISI 410 (12U)	
10	Air Seal Bridge G10-11 (4U)	
11	Panel (2U)	

12	Bumper (4U)	
13	PH-FH #10-16 x 3/4' SMS, AISI 316 (8U)	
14	Roller Adjust Hole Plug (4U)	
15	Bottom Panel Guide (2U)	
16	Top Panel Guide (2U)	
17	Striker (1U)	
18	Lock Handle set (1U)	
19	PH-PH #10-16 x 1/2" SMS. AISI 316 (8U)	

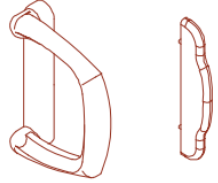

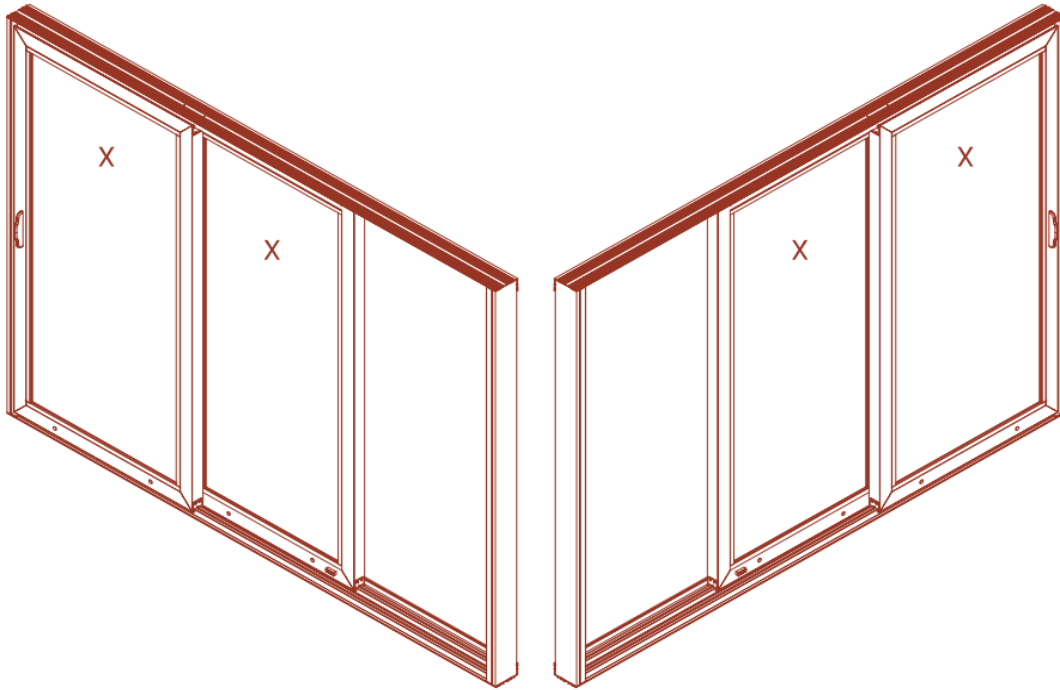

20	Pull Handel Set (IU)	
----	----------------------	-------------------------------------------------------------------------------------



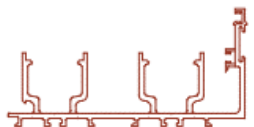
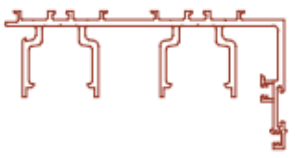
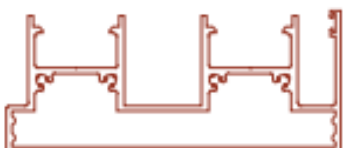

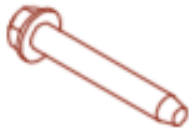
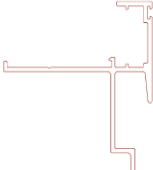
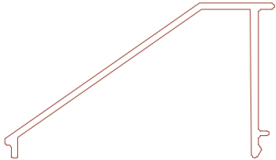

PXX Y XXP KD PAQUETE

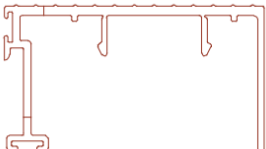
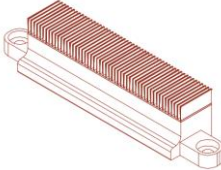

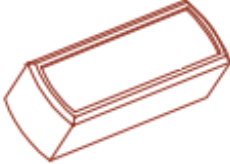
PARA LA CONFIGURACIÓN PXX / XXP VER PAGINAS
89-92 PARA LA SELECCIÓN DE TIPO DE PANEL

# Parte	Descripción	Imagen
1	Sill (1U)	
2	Head (1U)	
3	Jambs (2U)	

4	Hex Head #12 x 1 1/2" SMS. AISI 410 (16U)	
5	Hook Strip (1U)	
6	Hook Strip Cover (1U)	
7	Track Long (2U)	
8	Flat Cover Long (2U)	
9	PH-PH #10-16 x 1" Self Drilling. AISI 410 (12U)	
10	Vertical cover (1U)	
11	Air Seal Bridge G10-11 (2U)	

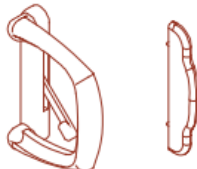
12	Panel (2U)	
13	Bumper (4U)	
14	PH-FH #10-16 x 3/4' SMS, AISI 316 (8U)	
15	Roller Adjust Hole Plug (4U)	
16	Bottom Panel Guide (2U)	
17	Top Panel Guide (2U)	
18	Striker (1U)	
19	Lock Handle set (1U)	

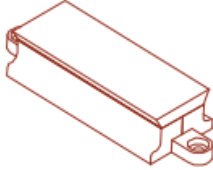
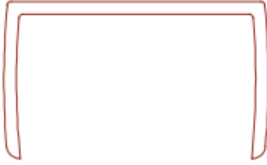
20	PH-PH #10-16 x 1/2" SMS. AISI 316 (8U)	
21	Air Seal Bridge G10-09 (2U)	
22	Drainage cover (1U)	

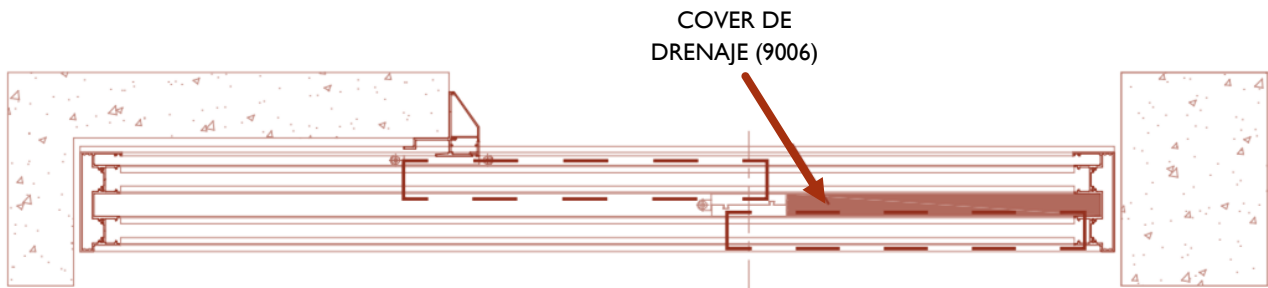

CONFIGURACIÓN PXX

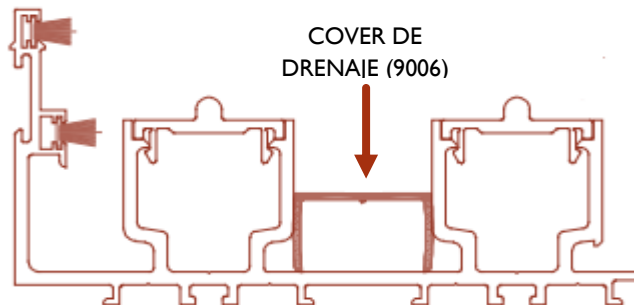
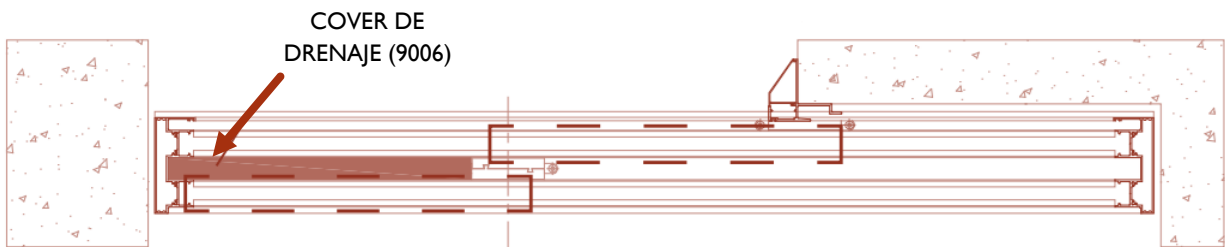







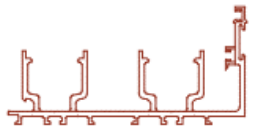
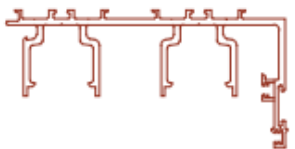
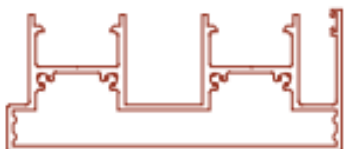

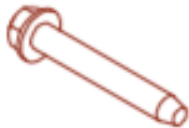
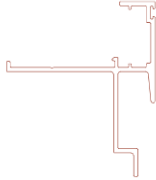
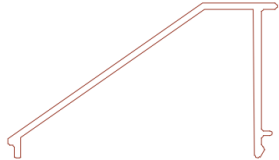



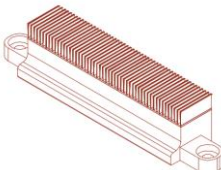

PXXXXP KD PAQUETE

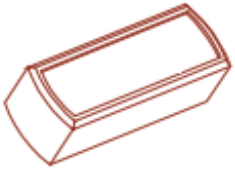

PARA LA CONFIGURACIÓN PXXXXP VER PAGINAS
89-92 PARA LA SELECCIÓN DE TIPO DE PANEL

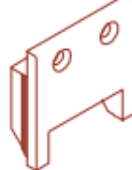
# Parte	Descripción	Imagen
1	Sill (1U)	
2	Head (1U)	
3	Jams (2U)	

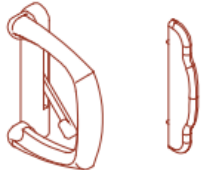
4	Hex Head #12 x 1 1/2" SMS. AISI 410 (16U)	
5	Hook Strip (2U)	
6	Hook Strip Cover (2U)	
7	Track Long (2U)	
8	Flat Cover Long (2U)	
9	PH-PH #10-16 x 1" Self Drilling. AISI 410 (20U)	
10	Air Seal Bridge G10-11 (4U)	
11	Panel (4U)	

12	Bumper (8U)	
13	PH-FH #10-16 x 3/4' SMS, AISI 316 (24U)	
14	Roller Adjust Hole Plug (8U)	
15	Bottom Panel Guide (6U)	
16	Top Panel Guide (6U)	
17	Striker (1U)	
18	Lock Handle set (1U)	
19	PH-PH #10-16 x 1/2" SMS. AISI 316 (16U)	

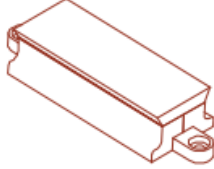
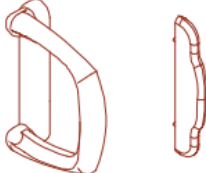
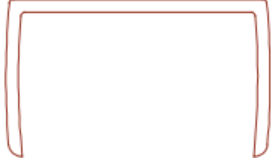
20	Air Seal Bridge (4U)	
21	Pull Handle Set (1U)	
22	Drainage cover (1U)	

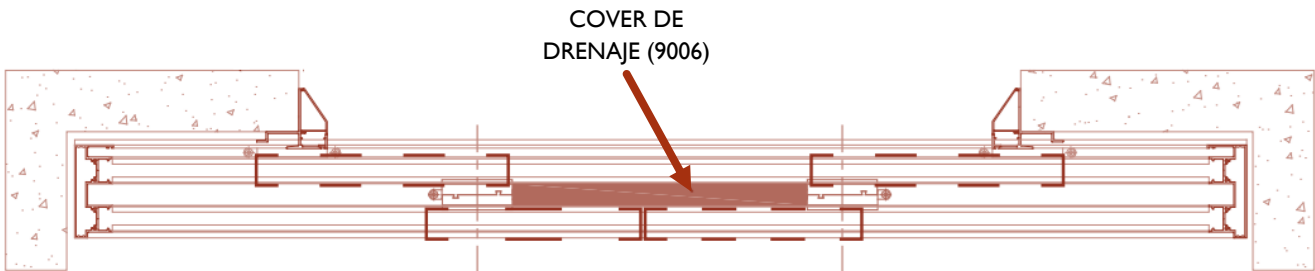

CONFIGURACIÓN XXP

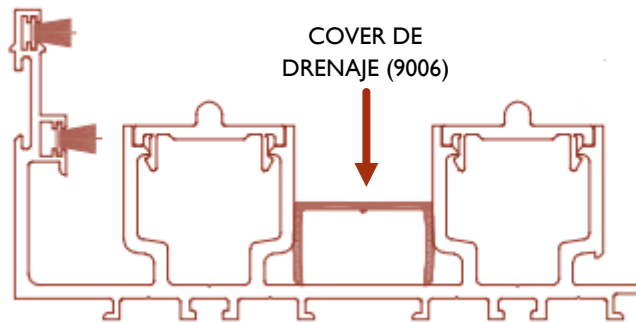

TIPOS DE CONFIGURACIONES

XO

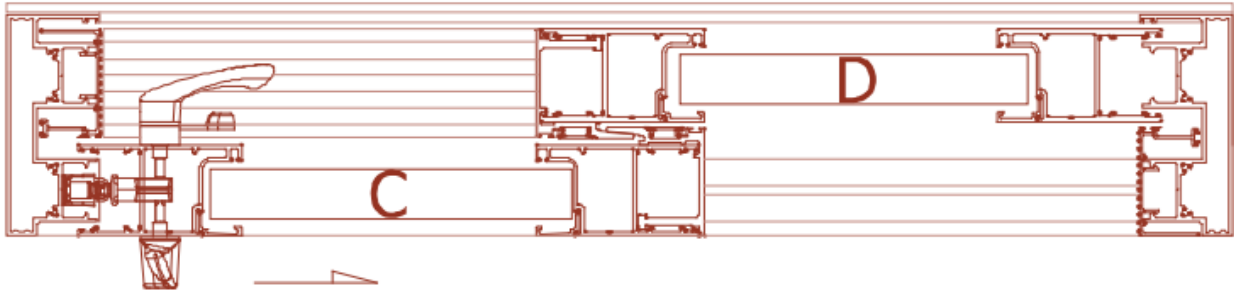

OX

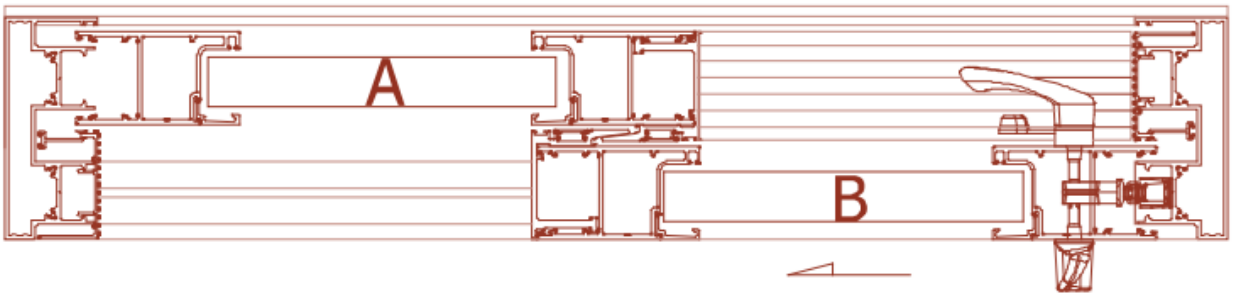

XX (REVERSE)

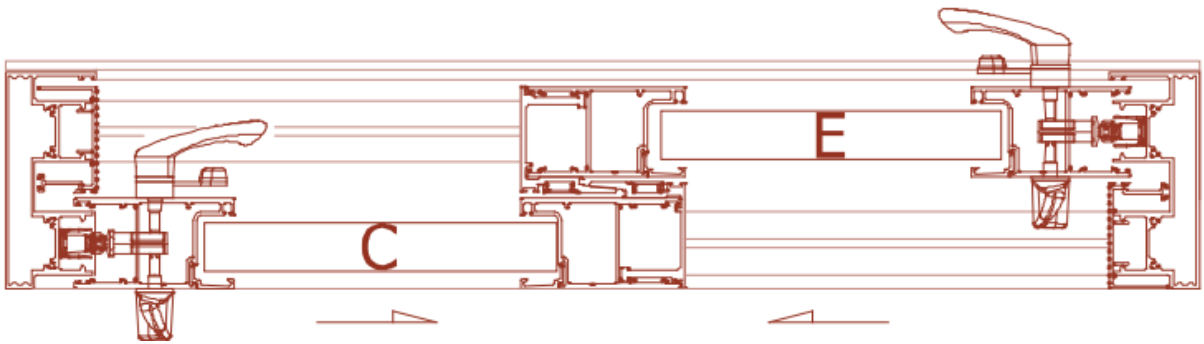

XX (STANDARD)

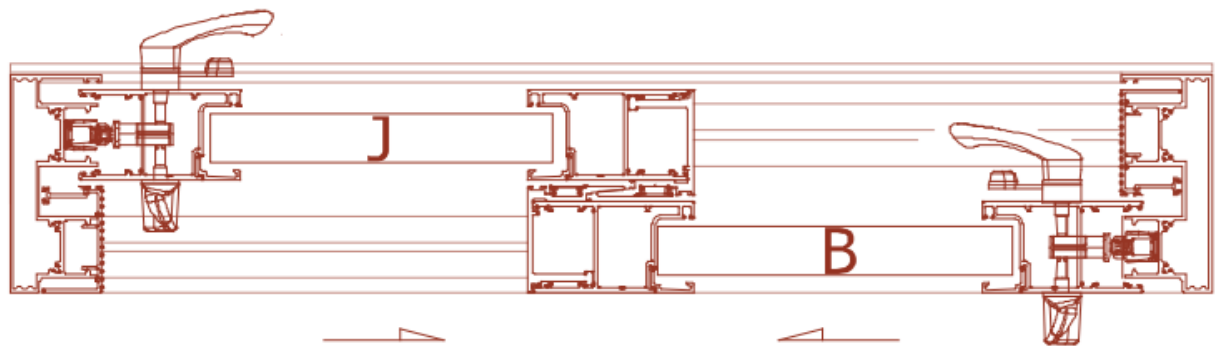

XOX

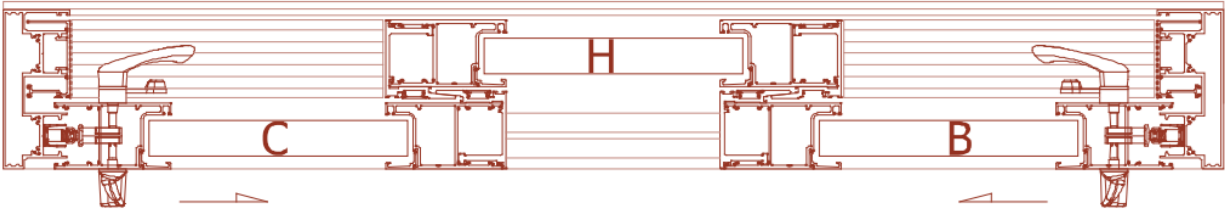

OXO w/STD> ASTRAGAL (REVERSE)

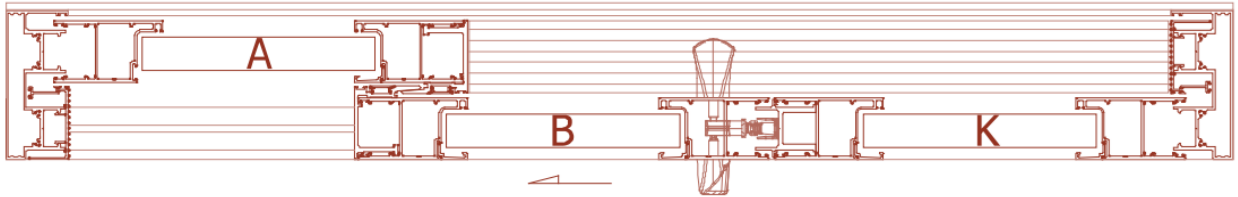

OXO w/REINF. ASTRAGAL (REVERSE)

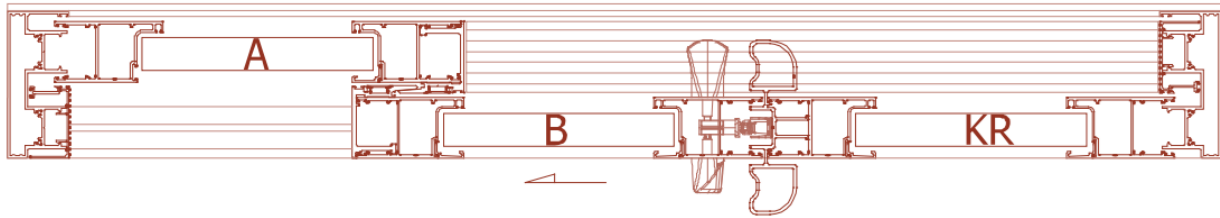

OXO w/REINF. ASTRAGAL

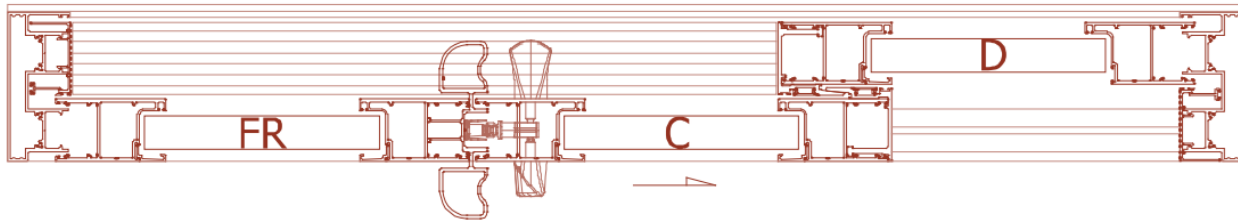

OXO w/STD. ASTRAGAL

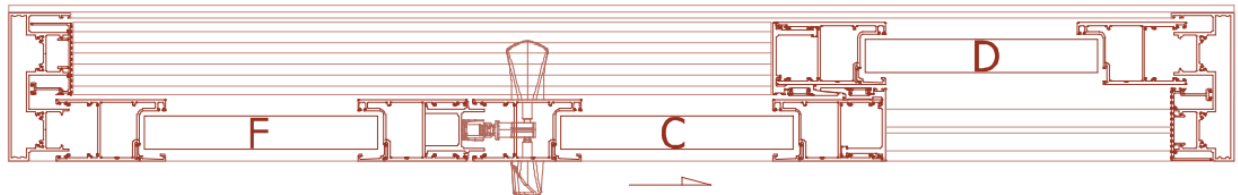

OXXO w/REINF. ASTRAGAL (REVERSE)

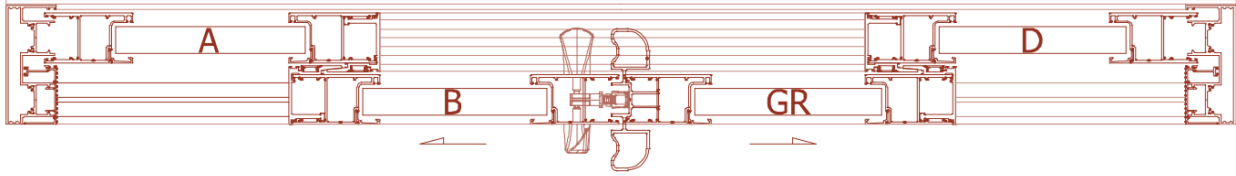

OXXO w/STD. ASTRAGAL (REVERSE)

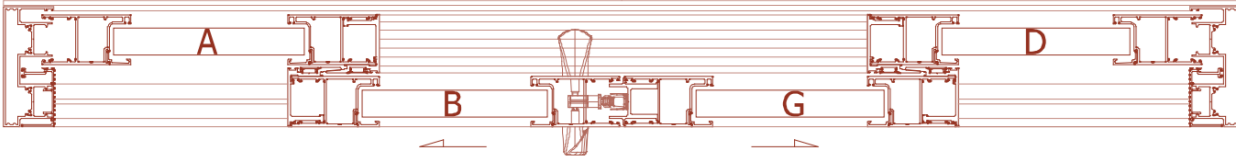

OXXO w/REINF. ASTRAGAL

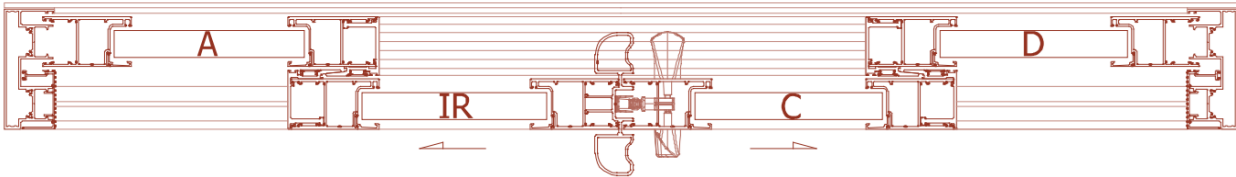

OXXO w/STD> ASTRAGAL

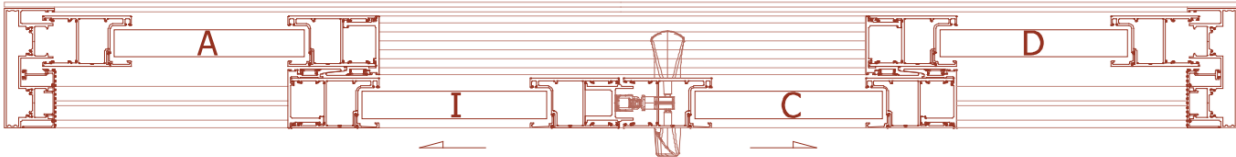

POCKET XP STD.

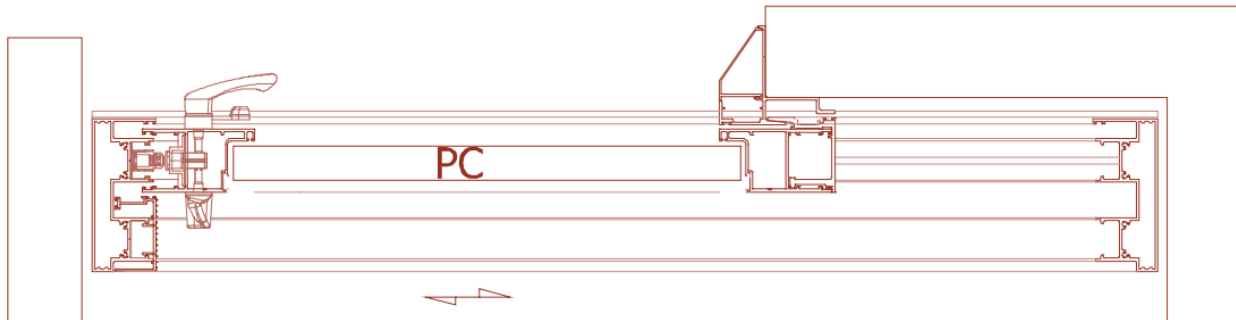

POCKET XP STD.

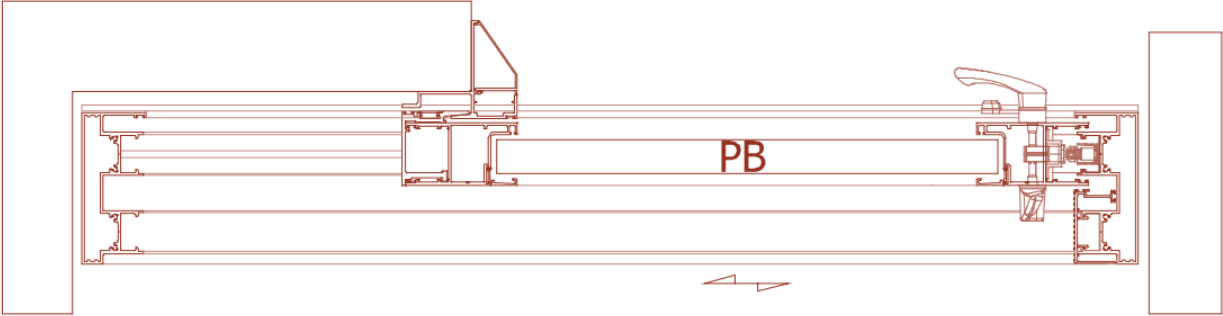

POCKER XXP STD.

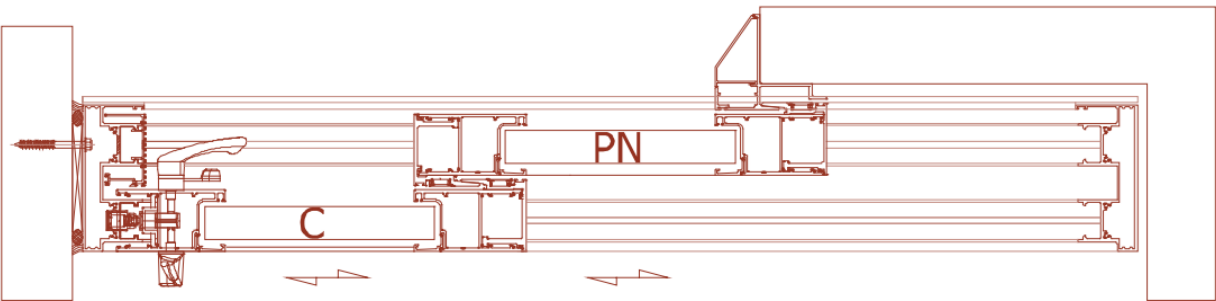

POCKET PXX STD.

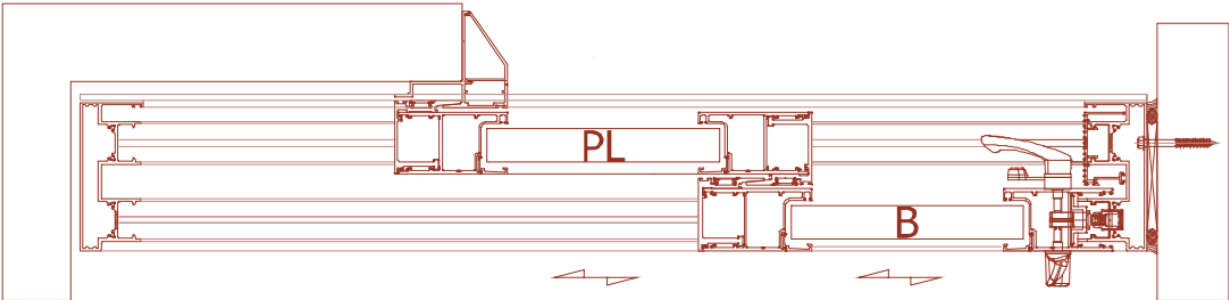

POCKET PXXP BYPART STD.

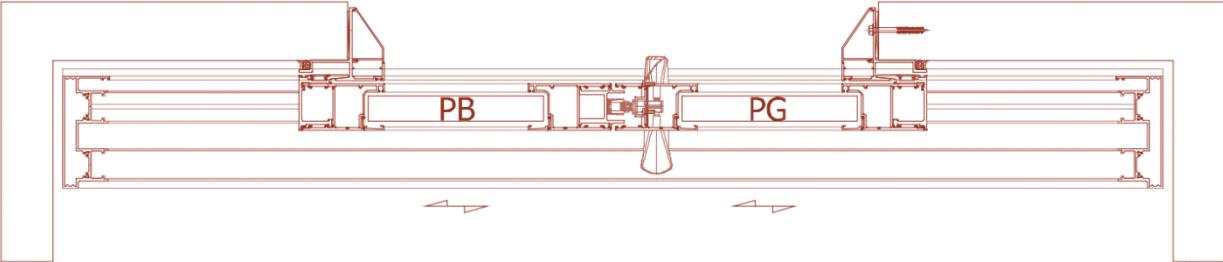

POCKET PXXP BYPART REVERSE

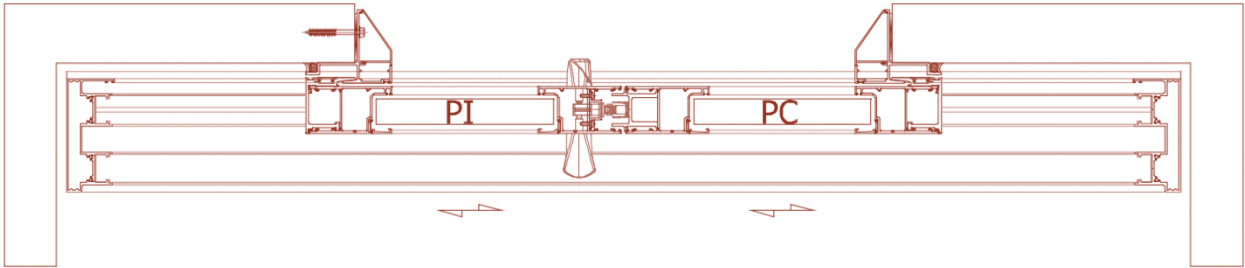

POCKET PXXP BYPART STD. w/REINF. ASTRAGAL

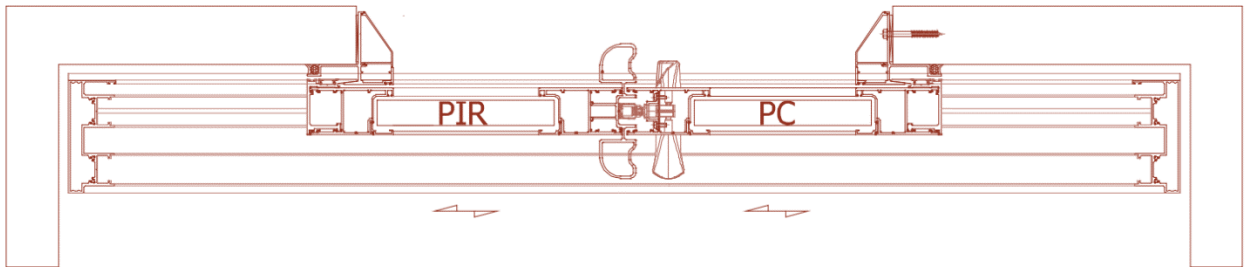

POCKET PXXP BYPART STD. W/REINF. ASTRAGAL (REVERSE)

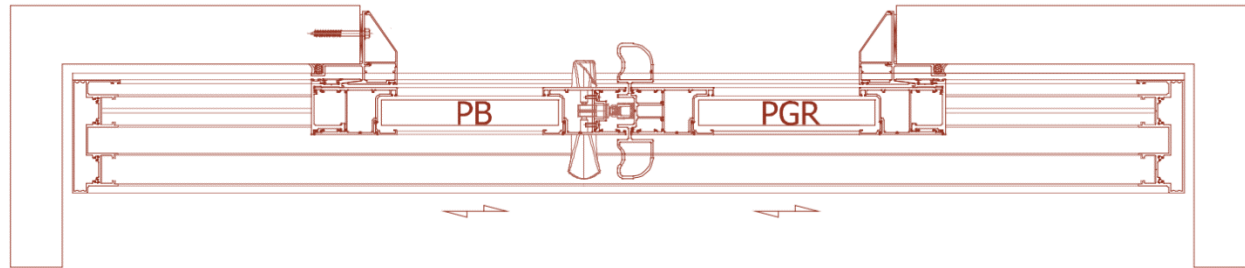

POCKET PXXXXP STD.

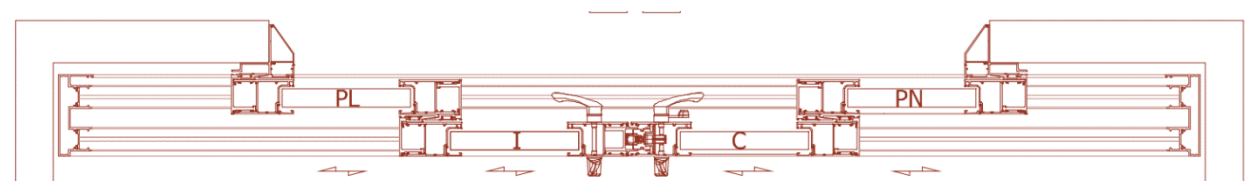

POCKET PXXXXP STD. w/REINF. ASTRAGAL

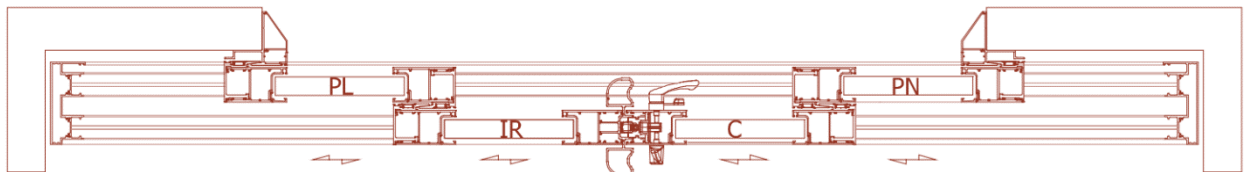

POCKET PXXXXP REVERSE

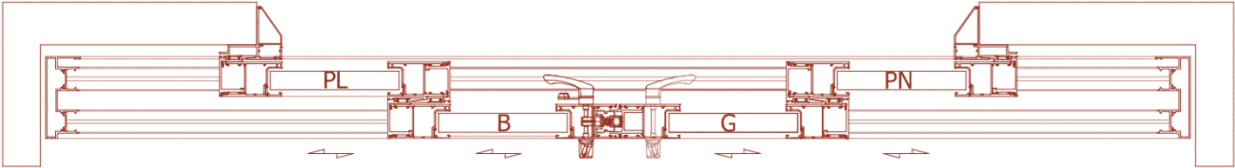

POCKET PXXXXP REVERSE w/REINF. ASTRAGAL

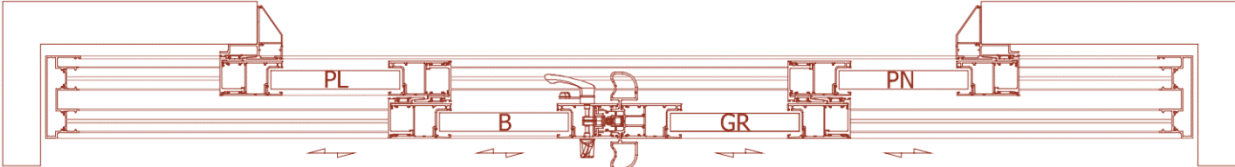

TIPOS DE PANELES

